



LUTOS a. s.
Rootsova dmychadla



INVESTOR IN PEOPLE



EN ISO 9001:2000 / EN ISO 14001:2004
Certificates No. 41006236/000-E1,
0410420049025/000-E1



KATALOG STANDARDNÍCH AGREGÁTŮ S ROOTSOVÝM DMYCHADLEM ŘADY DT

PŘETLAK

Platnost od 1/2006

CATALOGUE OF STANDARD P.D. BLOWER PACKAGES OF THE RANGE DT

PRESSURE

Validity from 1/2006

STANDARDAGGREGATENKATALOG MIT DREHKOLBENGEBLÄSE DER REIHE DT

ÜBERDRUCK

Gültig ab 1/2006

**КАТАЛОГ СТАНДАРТНЫХ НАГНЕТАТЕЛЬНЫХ АГРЕГАТОВ С РОТАЦИОННЫМ
НАГНЕТАТЕЛЕМ СЕРИИ DT**

ИЗБЫТОЧНОЕ ДАВЛЕНИЕ

Действует с 1/2006



☎ Dmychadlová soustrojí ve standardním provedení

Použití: Pro bezolejovou dopravu a stlačování vzduchu a neutrálních plynů

Provedení: Soustrojí jsou kompletována se základním příslušenstvím, potřebným pro bezporuchový provoz. Pohon dmyhadla je elektromotorem, u dvou nejmenších velikostí přímo s pružnou spojkou, u ostatních velikostí pomocí převodu klínovými řemeny.

Základní vybavení

1. Dmyhadlo s třízubými rotory; u velikostí DT 4 a DT 4R s rotory dvouzubými
2. Elektromotor
3. Nosný rám s tlumičem stlačeného vzduchu (kromě velikosti DT4)
4. Tlumič a filtr sání
5. Řemenový převod u DT 4R až DT 120/1002, spojka u DT 4
6. Kryt řemenového převodu, pokud není soustrojí kompletováno s protihlukovým krytem
7. Pojistný ventil Herose u velikostí DT 6/42 až DT 50/72
8. Kombinovaný pojistný a rozběhový ventil u velikostí DT 50/102 a větších od tlaku 30 kPa
9. Zpětná klapka na výtlaku
10. Kompenzátor od velikosti DT 6/42
11. Vizuální indikátor zanesení filtru od vel. DT10/42 (V případě kompletace s protihlukovým krytem místo indikátoru podtlakový manometr)
12. Manometr na výtlaku od vel. DT 6/42
13. 1× kompletní technická dokumentace

Zvláštní příslušenství

1. Pojistný ventil – pro typy DT 4 a DT 4R
2. Vizuální signalizace zanesení filtru DT 6/42
3. Protihlukový kryt
4. Protihlukový kryt včetně elektrické řídicí jednotky (spouštění, signalizace poruch, kontrola teploty a tlaku vzduchu)
5. Podtlakový manometr místo vizuálního indikátoru zanesení filtru
6. Snímače tlaků a teplot pro sledování a ochranu provozu
7. Elektrická řídicí jednotka v samostatné skříni (funkce shodné jako u bodu 4)
8. Frekvenční měniče

Inženýrské služby

1. Software na určení optimálního typu a výkonnosti dmyhadla, příkonu, teploty vzdušiny na výtlaku z dmyhadla, optimalizace elektromotoru,...
2. Poradenská činnost v oblasti rozvodů stlačeného vzduchu
3. Výpočty nucené ventilace strojovny

Klimatické podmínky

Klimatické provedení výrobku: WT ČSN EN 60721-3-3

Kategorie umístění výrobku: ČSN EN 60721-3-3
3K7L, 3B1, 3C3, 3S2, 3M3

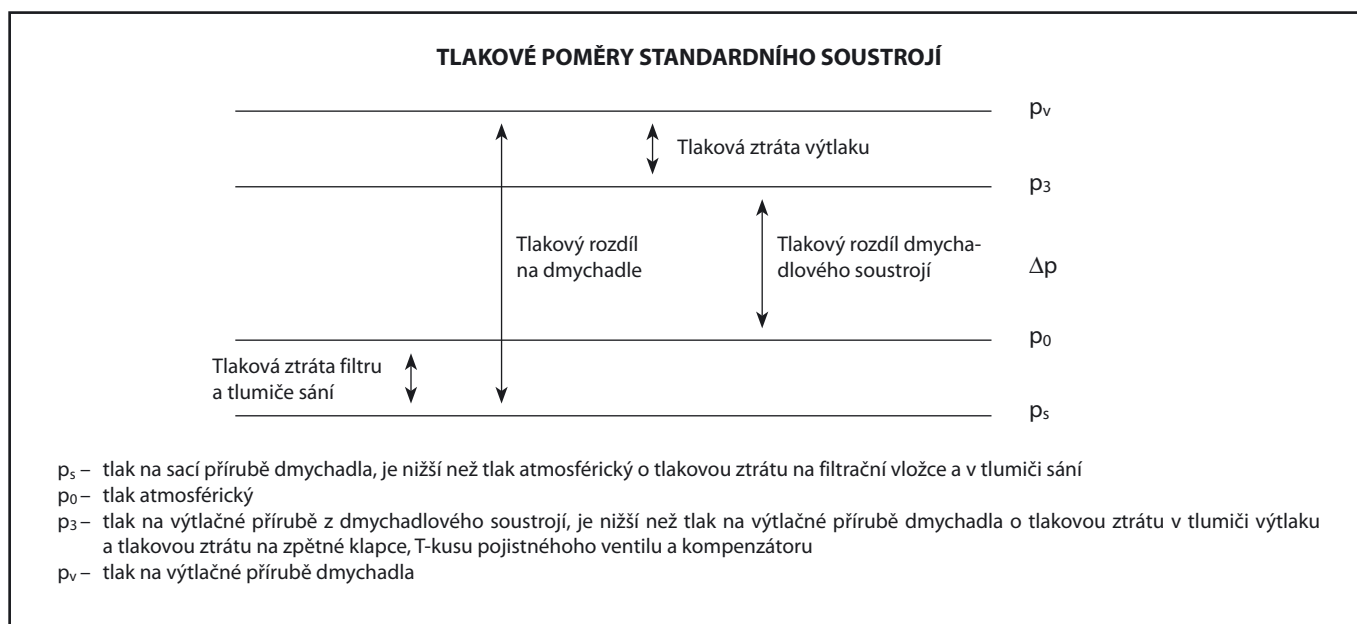

Katalog je aktualizován 1× ročně. Vzhledem k vývoji a zlepšování užitečných vlastností výrobků LUTOS může v průběhu této doby dojít k drobným změnám údajů uvedených v katalogu. Doporučujeme proto konkrétní údaje ověřit v aktualizovaném katalogu ve formátu PDF na stránkách www.lutos.cz.

UK Standard blower packages

Usage: For oilfree transport and pressure of air and neutral gasses

Model: Blower packages are assembled with basic equipment necessary for malfunction free operation. Blowers are driven by electromotor, for DT 4 directly by flexible coupling, for other blower packages by V-belts.

Basic equipment

1. Blower DI 6 – DI 120 (3 lobe rotors), DI 4 and DT 4R (2 lobe rotors)
2. El-motor
3. Supporting frame with discharge silencer except DT 4
4. Filter and suction silencer
5. Belt drive for DT 4R up to DT 120/1002, coupling for DT 4
6. Cover of belt drive, if the blower packages is not completed with sound enclosure
7. Safety valve Herose for DT 6/42 – DT 50/72
8. Integrated safety and start-up valve – for DT 50/102 - DT 120/1002 from pressure 30 kPa
9. Non-return flap valve on discharge
10. Compensator from DT 6/42
11. Visual filter clogging indicator – from DT 10/42 (Vacuum gauge instead of filter clogging indicator, if the blower package is completed with sound Enclosure)
12. Pressure gauge – control p_3 from DT 6/42
13. Complete technical documentation of blower packages

Accessories

1. Safety valve for DT 4 and DT 4R
2. Visual filter clogging indicator for DT 6/42
3. Sound enclosures
4. Sound enclosures with electro control system
5. Vacuum gauge instead of filter clogging indicator
6. Pressure and temperature sensors for blower protection
7. Electro control system in the separate box
8. Frequency convertor

Engineering Service

1. Software for determination of the optimal model and power of the blower, blower input power, temperature of the compressed air and optimum of electric motor, etc.
2. Consultation service in the branch of air distribution.
3. Calculation of the forced ventilation of the blower house

Air conditions

Air implementation of product: WT ČSN EN 60721-3-3
 Placement category of product: ČSN EN 60721-3-3
 3K7L, 3B1, 3C3, 3S2, 3M3

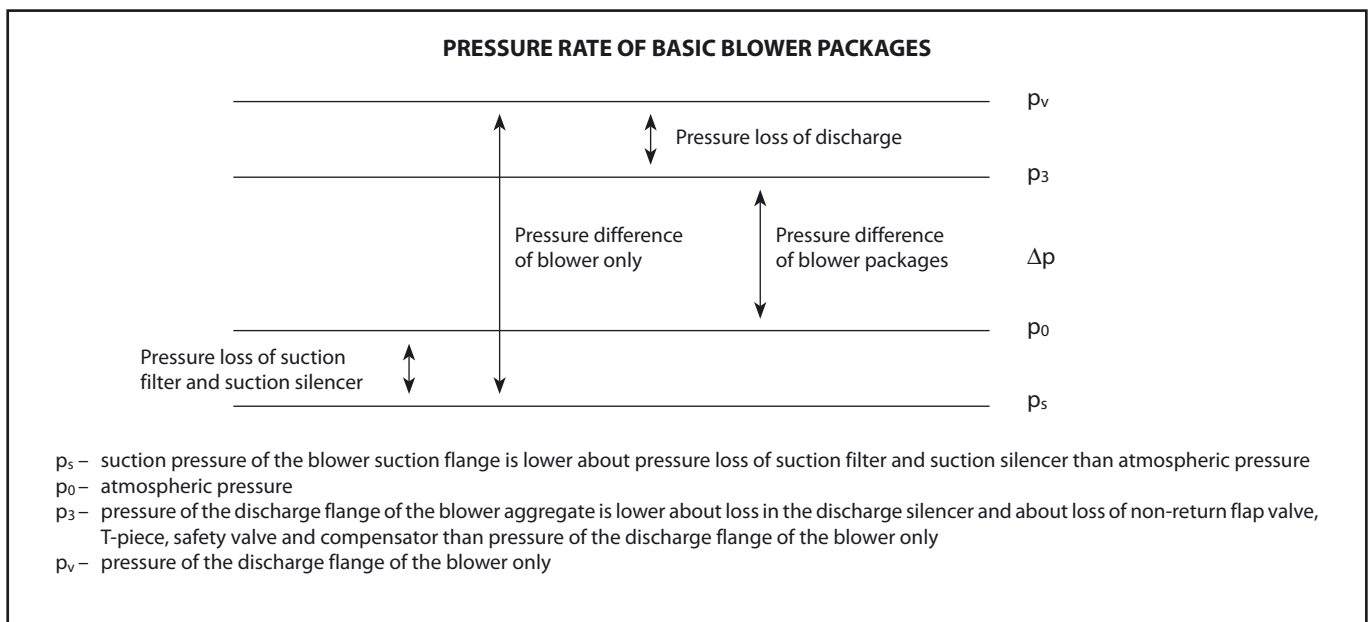

Our catalogue is updated once a year. In the view of development and improvement of product manufacture qualities Lutos' products, it is possible that some information can be slightly changed within a year. So we recommend you to verify particular data in our updated catalogue in PDF format on our web pages www.lutos.cz.

● Gebläseaggregate in der Standardausführung

Einsatzmöglichkeit: ölfreie Beförderung, Verdichtung der Luft und der neutralen Gase

Ausführung: die Aggregate werden mit Standardzubehör zusammengesetzt, welche für deren störungsfreien Betrieb erforderlich sind. Der Gebläseantrieb erfolgt durch Elektromotoren, bei den zwei kleinsten Gerätegrößen unmittelbar über eine elastische Kupplung, bei den anderen Gerätegrößen mittels eines Keilriemenantriebes.

Standardausstattung

1. Gebläse mit dreiflügeligen Rotoren, DT 4 und DT 4R mit zweiflügeligen Rotoren
2. Elektromotor
3. Tragerahmen mit Druckluftdämpfer (außer den Typen DT 4)
4. Saugdämpfer und Filter
5. Riemenantrieb beim Typ DT 4R bis DT 120/1002
6. Riemenschutz, falls das Aggregat nicht mit Schallschutzhaube ausgestattet ist
7. Herose-Sicherheitsventil (DT 6/42 bis DT 50/72)
8. Kombiniertes Sicherheits- und Anlaufventil bei den Größen ab DT 50/102
9. Rückschlagklappe auf der Austrittsseite
10. Kompensator ab der Größe DT 6/42
11. Optischer Anzeiger der Filterverschmutzung ab der Größe DT 10/42 (Unterdruck-Manometer anstelle des optischen Anzeigers der Filterverschmutzung immer bei Ausführung mit Schallschutzhaube)
12. Manometer auf dem Austritt ab der Größe DT 6/42
13. Vollständige technische Dokumentation

Sonderzubehör

1. Sicherheitsventil für die Typen DT 4 und DT 4R
2. Optischer Anzeiger der Filterverschmutzung bei den Typen DT 6/42
3. Schallschutzhaube
4. Elektrische Steuereinheit in Verbindung mit der Schallschutzhaube
5. Unterdruck-Manometer anstelle des optischen Anzeigers der Filterverschmutzung
6. Druck- und Temperatursensoren für die Betriebsüberwachung und -sicherung
7. Elektrische Steuereinheit im Einzelsteuerschrank
8. Frequenzumformer

Ingenieurdienstleistungen

1. Software – Auslegungsprogramm für Festlegung der optimaler Leistung des Gebläses, der Lufttemperatur am Austritt, Optimierung des Electromotors, ...
2. Beratungstätigkeit im Bereich der Druckluftverteilung
3. Berechnungen der künstlichen Lüftung des Maschinenraumes

Klimabedingungen:

Klimaausführung des Produktes: WT ČSN EN 60721-3-3
 Kategorie der Lokalisation des Produktes: ČSN EN 60721-3-3
 7L, 3B1, 3C3, 3S2, 3M3

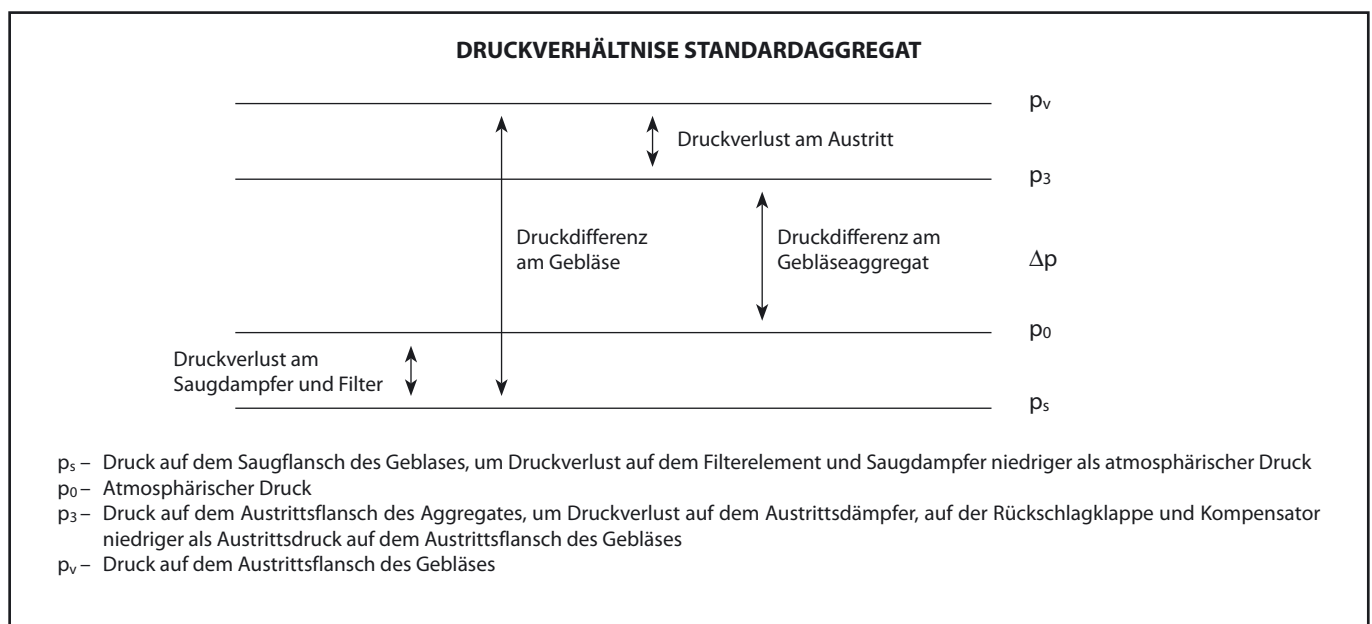

Der Katalog ist einmal jährlich aktualisiert. In Beziehung auf Entwicklung und Verbesserung Gebrauchseigenschaften LuToS Produkten kann im Laufe des Jahres zu kleinen Angabenänderungen in der Katalog kommen. Deshalb empfehlen wir die Konkreteangaben im Format PDF auf den Seiten www.lutos.cz überprüfen.

RU Нагнетательные агрегаты в стандартном исполнении

Использование: Для безмасляной транспортировки и сжатия воздуха и нейтральных газов.

Исполнение: Агрегаты комплектованы с основными принадлежностями, необходимыми для безаварийной эксплуатации. Нагнетатель приводится в движение электродвигателем, у самого малого размера - прямо с упругим сцеплением, у других - при помощи передачи с клиновидными ремнями.

Основное оборудование

1. Нагнетатель с трёхзубыми роторами; у размера «DT 4» и «DT 4R» с двухзубыми роторами
2. Электродвигатель
3. Несущая рама с демпфером сжатого воздуха (кроме размера «DT 4»)
4. Демпфер и фильтр всасывания
5. Ременная передача от «DT 4R»
6. Крышка ременной передачи, если агрегат не укомплектован противозвонным кожухом
7. Предохранительный клапан «Herose» у размеров «DT 6/42» – «DT 50/72»
8. У размеров «DT 50/102» и «DT 60/102» предохранительный клапан «Herose» или комбинированный предохранительный и пусковой клапан «PVO» согласно требованиям заказчика (при необходимости применения). Клапан «PVO» только от давления 30 кПа.
9. Обратный клапан на стороне нагнетания
10. Компенсатор от размера «DT 6/42»

11. Визуальный индикатор засорённости фильтра от размера «DT 10/42» (Манометр низкого давления вместо визуального индикатора засорённости фильтра, если агрегат укомплектован противозвонным кожухом)
12. Манометр на стороне нагнетания от размера «DT 6/42».
13. 1 комплект технической документации

5. Манометр низкого давления вместо визуального индикатора засорённости фильтра.
6. Датчики давлений и температур для наблюдения и охраны при эксплуатации.
7. Электрическое управляющее устройство в отдельной коробке (функция та же, что и в пункте 4).
8. Преобразователь частоты

Специальные принадлежности

1. Предохранительный клапан – для типов «DT 4» и «DT 4R»
2. Визуальная сигнализация засорённости фильтра у «DT 6/42»
3. Противозвонный кожух
4. Противозвонный кожух, включая электрическое управляющее устройство (запуск, сигнализация неполадок, контроль температуры и давления)

Инженерные службы

1. Программное обеспечение для определения оптимального типа и производительности нагнетателя, потребляемой мощности, температуры медиума на стороне нагнетания, оптимизации электродвигателя,...
2. Консультационная деятельность в области развода сжатого воздуха.
3. Расчёты принудительной вентиляции машинного зала.

Климатические условия

Климатическое исполнение изделия: WT ČSN EN 60721-3-3
Категория размещения изделия: ČSN EN 60721-3-3
7L, 3B1, 3C3, 3S2, 3M3

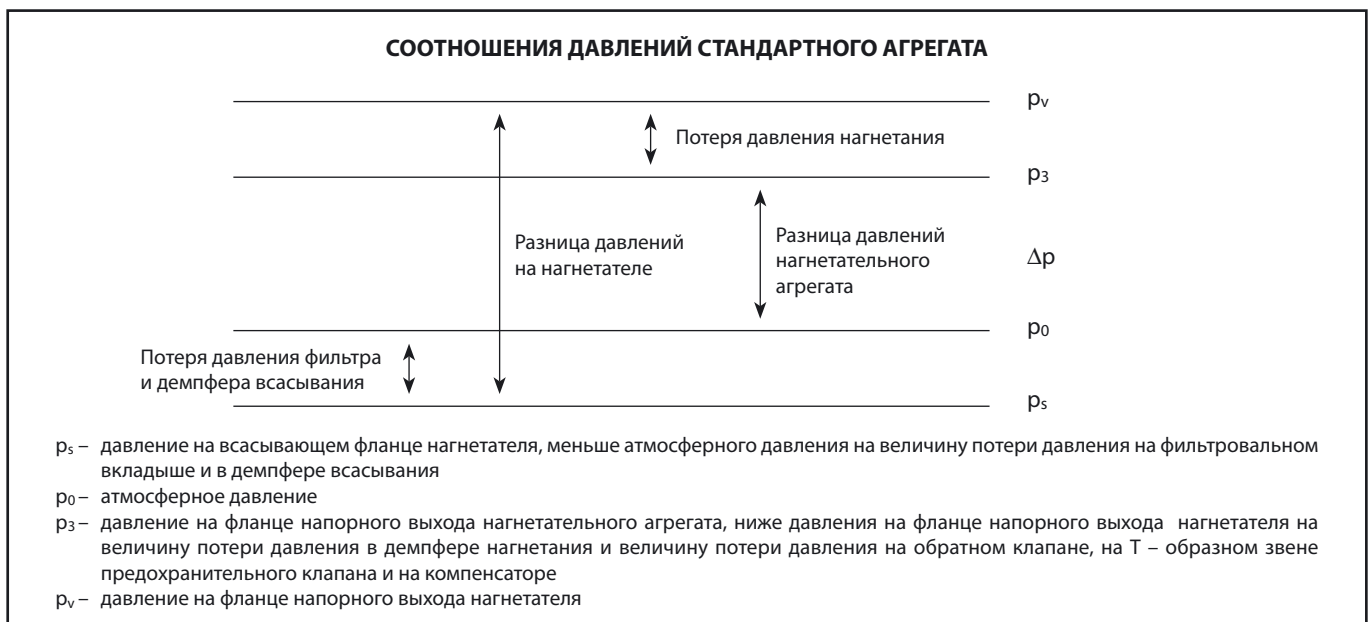

Каталог актуализируется один раз в год. Учитывая развитие и улучшение потребительских свойств изделий фирмы ЛУТОС, могут по ходу времени, возникнуть некоторые мелкие отклонения от данных, приведенных в каталоге. В связи с этим рекомендуем проверить конкретные данные изделий в постоянн актуализированном каталоге и формате PDF на сайтах www.lutos.cz.

CZ Q [m³·h⁻¹] – Výkonnost dmychadlového soustrojí (±10%)
 Δp [kPa] – Tlaková diference
 T₃ [°C] – Teplota na výtačné přírubě
 P_e [kW] – Příkon dmyhadla
 P_m [kW] – Výkon motoru
 n [min⁻¹] – Otáčky dmyhadla
 n_m [min⁻¹] – Otáčky motoru
 Elmotor – Osová výška a počet pólů elektromotoru
 i [mm] – Průměr řemenice motoru / Průměr řemenice dmyhadla
 X – Počet a druh klínových řemenů
 L_{mA} [dB] – Hladina akustického tlaku soustrojí s krytem a bez krytu
 p₀ = 101 kPa, t₁ = 20 °C, N_v = 0 m / nad mořem, suchý vzduch
 Δp = p₁ – p₃

UK Q [m³·h⁻¹] – Capacity of blower packages (±10%)
 Δp [kPa] – Pressure difference
 T₃ [°C] – Temperature on the discharge
 P_e [kW] – Blower input
 P_m [kW] – Motor load
 n [min⁻¹] – Blower speed
 n_m [min⁻¹] – Motor speed
 Elmotor – Frame size of elektromotor, number of pole
 i [mm] – Diameter of pulley – motor / blower
 X – Number and type of V-belts
 L_{mA} [dB] – Level of acoustic pressure with and without noise enclosure
 p₀ = 101 kPa, t₁ = 20 °C, N_v = 0 m / sea level, dry air
 Δp = p₁ – p₃

D Q [m³·h⁻¹] – Ansaugvolumenstrom (±10%)
 Δp [kPa] – Druckdifferenz
 T₃ [°C] – Endtemperatur am Austrittsflansch
 P_e [kW] – Gebläseleistungsbedarf
 P_m [kW] – Motornennleistung
 n [min⁻¹] – Gebläsedrehzahl
 n_m [min⁻¹] – Motordrehzahl
 Elmotor – Achsenhöhe und Polzahl
 i [mm] – Durchmesser (Motorriemenscheibe / Gebläseriemenscheibe)
 X – Zahl und Typ von Riemen
 L_{mA} [dB] – Schalldruckpegel für Gebläseaggregat mit Haube / ohne Haube
 p₀ = 101 kPa, t₁ = 20 °C, N_v = 0 m / Höhe über dem Meeresspiegel = 0 m, trockene Luft
 Δp = p₁ – p₃

RU Q [m³·h⁻¹] – Расход [м³·час⁻¹] (±10%)
 Δp [kPa] – Разница давлений [кПа]
 T₃ [°C] – Температура на выходе [°C]
 P_e [kW] – Мощность нагнетателя [кВт]
 P_m [kW] – Мощность электродвигателя [кВт]
 n [min⁻¹] – Частота вращения нагнетателя [об/мин]
 n_m [min⁻¹] – Частота вращения электродвигателя [об/мин]
 Elmotor – Электродвигатель
 i [mm] – Ременные шкивы – электродвигатель / нагнетатель
 X – Количество ремней
 L_{mA} [dB] – Уровень шума [дБ] с кожухом/ без кожуха
 p₀ = 101 kPa, t₁ = 20 °C, 0 м/н. у. моря, сухой воздух
 Δp = p₁ – p₃

CZ Dmychadlová soustrojí pro přetlak
UK Blower packages for pressure
D Gebläseaggregate für Überdruck
RU Нагнетательные агрегаты

DT 4
DT 4R



Δp [kPa]	Elmotor P _m [kW] n _m [min ⁻¹] i X n [min ⁻¹]	DT 4 DN 3/4"		DT 4R DN 1"				
		71-2 0,55 2800 – – 2800	71-2 0,55 2800 80/71 1/XPZ 3155	90/71 3549	100/71 3944	80/71 1/XPZ 3217	90/71 1/XPZ 3619	100/71 1/XPZ 4021
5	Q [m ³ ·h ⁻¹]	27	31	36	40	32	37	41
	T ₃ [°C]	25	25	25	26	25	25	26
	P _e [kW]	0,1	0,1	0,1	0,1	0,1	0,1	0,1
	L _{mA} [dB]	56/73	62/74	63/75	64/76	62/74	63/75	64/76
10	Q [m ³ ·h ⁻¹]	25	30	34	39	31	35	40
	T ₃ [°C]	31	30	30	30	30	30	30
	P _e [kW]	0,1	0,1	0,1	0,2	0,1	0,1	0,2
	L _{mA} [dB]	57/74	64/75	65/76	66/77	64/75	65/76	66/77
15	Q [m ³ ·h ⁻¹]	24	29	33	38	30	34	39
	T ₃ [°C]	36	36	36	36	36	36	36
	P _e [kW]	0,1	0,2	0,2	0,2	0,2	0,2	0,2
	L _{mA} [dB]	58/74	64/76	65/77	66/78	64/76	65/77	66/78
20	Q [m ³ ·h ⁻¹]	23	28	32	37	29	33	38
	T ₃ [°C]	42	41	41	41	41	41	41
	P _e [kW]	0,2	0,2	0,3	0,3	0,2	0,3	0,3
	L _{mA} [dB]	58/75	65/76	66/77	67/78	65/76	66/77	67/78
25	Q [m ³ ·h ⁻¹]	23	27	32	36	28	33	37
	T ₃ [°C]	49	47	47	46	47	47	46
	P _e [kW]	0,2	0,3	0,3	0,3	0,3	0,3	0,4
	L _{mA} [dB]	59/76	65/77	66/78	67/79	65/77	66/78	67/79
30	Q [m ³ ·h ⁻¹]	22	27	31	35	27	32	36
	T ₃ [°C]	55	54	53	52	53	52	52
	P _e [kW]	0,3	0,3	0,4	0,4	0,3	0,4	0,4
	L _{mA} [dB]	59/77	65/78	66/79	67/80	65/78	66/79	67/80
35	Q [m ³ ·h ⁻¹]	21	26	30		27	31	36
	T ₃ [°C]	62	60	59		60	58	57
	P _e [kW]	0,3	0,4	0,4		0,4	0,4	0,5
	L _{mA} [dB]	60/78	66/79	67/80		66/79	67/80	68/81
40	Q [m ³ ·h ⁻¹]	21	25			26	31	35
	T ₃ [°C]	70	67			66	65	64
	P _e [kW]	0,4	0,4			0,4	0,5	0,55
	L _{mA} [dB]	61/79	66/80			66/80	67/81	68/81
45	Q [m ³ ·h ⁻¹]	20				26	30	35
	T ₃ [°C]	78				73	71	70
	P _e [kW]	0,411				0,5	0,55	0,61
	L _{mA} [dB]	61/79				66/80	67/81	68/81
50	Q [m ³ ·h ⁻¹]					25	30	34
	T ₃ [°C]					80	78	76
	P _e [kW]					0,54	0,61	0,68
	L _{mA} [dB]					66/81	67/81	68/81
55	Q [m ³ ·h ⁻¹]					25	29	
	T ₃ [°C]					88	84	
	P _e [kW]					0,6	0,67	
	L _{mA} [dB]					67/81	67/82	

- CZ Dmychadlová soustrojí pro přetlak
 UK Blower packages for pressure
 D Gebläseaggregate für Überdruck
 RU Нагнетательные агрегаты

DT 6/42



Δp [kPa]	DT 6/42 DN 65										
30	Q [m ³ ·h ⁻¹]									91	104
	T ₃ [°C]									48	48
	P _e [kW]									0,94	1,06
	P _m [kW]									1,5	1,5
	n [min ⁻¹]									4317	4856
	n _m [min ⁻¹]									2860	2860
	Elmotor i									90-2	90-2
X									160/106	180/106	
L _{mA} [dB]									1/XPZ	1/XPZ	
									78/88	79/91	
40	Q [m ³ ·h ⁻¹]				62	71	77	90	103		
	T ₃ [°C]				61	60	63	58	58		
	P _e [kW]				0,92	1,03	1,1	1,25	1,41		
	P _m [kW]				1,5	1,5	1,5	2,2	2,2		
	n [min ⁻¹]				3183	3561	3830	4347	4890		
	n _m [min ⁻¹]				2860	2860	2860	2880	2880		
	Elmotor i				90-2	90-2	90-2	90-2	90-2		
X				118/106	132/106	150/112	160/106	180/106			
L _{mA} [dB]				1/XPZ	1/XPZ	1/XPZ	1/XPZ	1/XPZ			
				78/88	79/89	79/90	80/91	81/93			
50	Q [m ³ ·h ⁻¹]				52	60	70	77	89	102	
	T ₃ [°C]				74	72	71	70	69	68	
	P _e [kW]				1,03	1,14	1,3	1,4	1,56	1,76	
	P _m [kW]				1,5	1,5	2,2	2,2	2,2	2,2	
	n [min ⁻¹]				2860	3183	3586	3857	4347	4891	
	n _m [min ⁻¹]				2860	2860	2880	2880	2880	2880	
	Elmotor i				90-2	90-2	90-2	90-2	90-2	90-2	
X				112/112	118/106	132/106	150/112	160/106	180/106		
L _{mA} [dB]				1/XPZ	1/XPZ	1/XPZ	1/XPZ	1/XPZ	1/XPZ		
				78/88	78/89	80/90	80/91	81/92	82/94		
60	Q [m ³ ·h ⁻¹]			34	41	52	60	69	76	88	102
	T ₃ [°C]			95	91	86	84	82	81	79	78
	P _e [kW]			0,92	1,05	1,23	1,38	1,54	1,66	1,9	2,2
	P _m [kW]			1,5	1,5	1,5	2,2	2,2	2,2	3	3
	n [min ⁻¹]			2135	2427	2860	3206	3586	3857	4362	4908
	n _m [min ⁻¹]			2860	2860	2860	2880	2880	2880	2890	2890
	Elmotor i			90-2	90-2	90-2	90-2	90-2	90-2	100-2	100-2
X			112/150	112/132	112/112	118/106	132/106	150/112	160/106	180/106	
L _{mA} [dB]			1/XPZ	1/XPZ	1/XPZ	1/XPZ	1/XPZ	1/XPZ	1/XPZ	1/XPZ	
			77/87	78/88	79/89	80/90	81/91	81/92	82/93	83/95	
70	Q [m ³ ·h ⁻¹]			31	40	51	59	69	75	87	101
	T ₃ [°C]			112	104	98	95	93	91	89	88
	P _e [kW]			1,01	1,22	1,45	1,6	1,8	1,92	2,2	2,5
	P _m [kW]			1,5	1,5	2,2	2,2	2,2	3	3	3
	n [min ⁻¹]			2021	2427	2880	3206	3586	3871	4362	4908
	n _m [min ⁻¹]			2860	2860	2880	2880	2880	2890	2890	2890
	Elmotor i			90-2	90-2	90-2	90-2	90-2	100-2	100-2	100-2
X			106/150	112/132	112/112	118/106	132/106	150/112	160/106	180/106	
L _{mA} [dB]			1/XPZ	1/XPZ	1/XPZ	1/XPZ	1/XPZ	1/XPZ	1/XPZ	1/XPZ	
			77/87	78/88	80/90	81/91	82/92	82/93	83/94	83/95	

Δp [kPa]	DT 10/42 DN 65											
	83	99	122	133	153	180	206	238	253	268	304	
30	Q [m ³ ·h ⁻¹]	83	99	122	133	153	180	206	238	253	268	304
	T ₃ [°C]	55	53	52	51	50	50	49	49	49	49	48
	P _e [kW]	1,1	1,2	1,4	1,5	1,7	2	2,2	2,5	2,6	2,8	3,2
	P _m [kW]	1,5	1,5	2,2	2,2	2,2	3	3	4	4	4	4
	n [min ⁻¹]	2021	2296	2688	2880	3214	3673	4128	4668	4923	5187	5810
	n _m [min ⁻¹]	2860	2860	2880	2880	2880	2890	2890	2905	2905	2905	2905
	Elmotor	90-2	90-2	90-2	90-2	90-2	100-2	100-2	112-2	112-2	112-2	112-2
	i	106/150	106/132	140/150	125/125	125/112	150/118	160/112	180/112	200/118	200/112	200/100
	X	1/XPZ	1/XPZ	1/XPZ	1/XPZ	1/XPZ	1/XPZ	1/XPA	1/XPA	1/XPA	1/XPA	1/XPA
	L _{mA} [dB]	69/83	70/88	71/89	71/89	72/91	73/92	73/92	74/93	75/94	76/96	81/102
40	Q [m ³ ·h ⁻¹]	79	95	118	129	149	176	203	233	250	266	302
	T ₃ [°C]	70	67	64	64	62	60	60	59	59	59	58
	P _e [kW]	1,4	1,6	1,9	2	2,3	2,6	3	3,3	3,5	3,7	4,2
	P _m [kW]	2,2	2,2	3	3	3	4	4	4	5,5	5,5	5,5
	n [min ⁻¹]	2035	2312	2697	2890	3225	3692	4150	4668	4957	5223	5850
	n _m [min ⁻¹]	2880	2880	2890	2890	2890	2905	2905	2905	2925	2925	2925
	Elmotor	90-2	90-2	100-2	100-2	100-2	112-2	112-2	112-2	132-2	132-2	132-2
	i	106/150	106/132	140/150	125/125	125/112	150/118	160/112	180/112	200/118	200/112	200/100
	X	1/XPZ	1/XPZ	1/XPZ	1/XPA	1/XPA	1/XPA	1/XPA	1/XPA	1/XPA	1/XPA	1/XPA
	L _{mA} [dB]	70/83	71/89	71/90	72/91	73/92	73/92	74/93	75/94	76/96	77/97	82/103
50	Q [m ³ ·h ⁻¹]	74	91	114	126	146	172	201	232	247	262	298
	T ₃ [°C]	85	74	77	75	73	71	70	69	69	69	68
	P _e [kW]	1,8	2	2,3	2,5	2,8	3,2	3,7	4,2	4,4	4,6	5,5
	P _m [kW]	2,2	3	3	4	4	4	5,5	5,5	5,5	5,5	7,5
	n [min ⁻¹]	2035	2312	2697	2905	3242	3692	4178	4700	4957	5223	5860
	n _m [min ⁻¹]	2880	2890	2890	2905	2905	2905	2925	2925	2925	2925	2930
	Elmotor	90-2	100-2	100-2	112-2	112-2	112-2	132-2	132-2	132-2	132-2	132-2
	i	106/150	112/140	140/150	125/125	125/112	150/118	160/112	180/112	200/118	200/112	200/100
	X	1/XPA	1/XPA	1/XPA	1/XPA	1/XPA	1/XPA	1/XPA	1/XPA	1/XPA	1/XPA	1/XPA
	L _{mA} [dB]	71/83	71/90	72/91	73/92	74/93	74/93	75/94	76/96	76/97	77/98	82/103
60	Q [m ³ ·h ⁻¹]	70	88	105	123	144	171	198	229	244	260	296
	T ₃ [°C]	103	96	82	88	85	83	81	79	79	79	78
	P _e [kW]	2,1	2,4	2,7	3	3,4	3,9	4,4	5	5,2	5,5	6,2
	P _m [kW]	3	3	4	4	5,5	5,5	5,5	7,5	7,5	7,5	7,5
	n [min ⁻¹]	2023	2312	2596	2905	3264	3718	4178	4708	4966	5232	5860
	n _m [min ⁻¹]	2890	2890	2905	2905	2925	2925	2925	2930	2930	2930	2930
	Elmotor	100-2	100-2	112-2	112-2	132-2	132-2	132-2	132-2	132-2	132-2	132-2
	i	112/160	112/140	118/132	125/125	125/112	150/118	160/112	180/112	200/118	200/112	200/100
	X	1/XPA	1/XPA	1/XPA	1/XPA	1/XPA	1/XPA	1/XPA	1/XPA	1/XPA	1/XPA	1/XPA
	L _{mA} [dB]	72/89	72/91	73/92	73/94	74/94	74/95	75/95	76/96	77/98	78/98	83/104
70	Q [m ³ ·h ⁻¹]	67	85	102	121	141	168	195	226	241	257	295
	T ₃ [°C]	121	111	106	101	98	94	92	90	89	90	88
	P _e [kW]	2,4	2,8	3	3,6	4	4,5	5,1	5,8	6,1	6,4	7,3
	P _m [kW]	3	4	4	5,5	5,5	5,5	7,5	7,5	7,5	7,5	11
	n [min ⁻¹]	2023	2324	2596	2925	3264	3718	4185	4708	4966	5232	5880
	n _m [min ⁻¹]	2890	2905	2905	2925	2925	2925	2930	2930	2930	2930	2940
	Elmotor	100-2	112-2	112-2	132-2	132-2	132-2	132-2	132-2	132-2	132-2	160-2
	i	112/160	112/140	118/132	125/125	125/112	150/118	160/112	180/112	200/118	200/112	200/100
	X	1/XPA	1/XPA	1/XPA	1/XPA	1/XPA	1/XPA	1/XPA	1/XPA	1/XPA	2/XPZ	2/XPZ
	L _{mA} [dB]	72/90	73/92	73/93	74/94	74/95	75/96	76/97	77/98	78/98	78/99	84/106
80	Q [m ³ ·h ⁻¹]		83	100	119	139	166	193	225	240	256	293
	T ₃ [°C]		128	120	114	110	106	103	101	100	100	98
	P _e [kW]		3,2	3,6	4	4,5	5,2	5,8	6,6	7	7,3	8,3
	P _m [kW]		4	5,5	5,5	5,5	7,5	7,5	11	11	11	11
	n [min ⁻¹]		2324	2614	2925	3264	3724	4185	4725	4983	5250	5880
	n _m [min ⁻¹]		2905	2925	2925	2925	2930	2930	2940	2940	2940	2940
	Elmotor		112-2	132-2	132-2	132-2	132-2	132-2	160-2	160-2	160-2	160-2
	i		112/140	118/132	125/125	125/112	150/118	160/112	180/112	200/118	200/112	224/112
	X		1/XPA	1/XPA	1/XPA	1/XPA	1/XPA	1/XPA	2/XPZ	2/XPZ	2/XPZ	2/XPZ
	L _{mA} [dB]		73/92	73/93	74/95	74/95	75/96	76/97	77/98	78/99	79/100	84/107
90	Q [m ³ ·h ⁻¹]			98	116	137	164	192	223	238	254	290
	T ₃ [°C]			135	128	123	118	114	112	111	111	108
	P _e [kW]			4,1	5	5,1	5,8	6,6	7,4	7,8	8,2	9,3
	P _m [kW]			5,5	5,5	7,5	7,5	11	11	11	11	11
	n [min ⁻¹]			2614	2925	3270	3724	4200	4725	4983	5250	5880
	n _m [min ⁻¹]			2925	2925	2930	2930	2940	2940	2940	2940	2940
	Elmotor			132-2	132-2	132-2	132-2	160-2	160-2	160-2	160-2	160-2
	i			118/132	125/125	125/112	150/118	160/112	180/112	200/118	200/112	224/112
	X			1/XPA	1/XPA	1/XPA	1/XPA	2/XPZ	2/XPZ	2/XPZ	2/XPZ	2/XPZ
	L _{mA} [dB]			74/95	74/95	75/96	76/97	77/98	78/99	79/100	80/101	84/106
100	Q [m ³ ·h ⁻¹]					135	162	190	221	236	252	
	T ₃ [°C]					136	130	126	123	123	120	
	P _e [kW]					5,7	6,5	7,3	8,2	8,7	9,2	
	P _m [kW]					7,5	7,5	11	11	11	11	
	n [min ⁻¹]					3270	3724	4200	4725	4983	5250	
	n _m [min ⁻¹]					2930	2930	2940	2940	2940	2940	
	Elmotor					132-2	132-2	160-2	160-2	160-2	160-2	
	i					125/112	150/118	160/112	180/112	200/118	200/112	
	X					1/XPA	1/XPA	2/XPZ	2/XPZ	2/XPZ	2/XPZ	
	L _{mA} [dB]					76/97	76/98	78/99	79/100	80/101	82/104	

Δp [kPa]	DT 20/42 DN 65											
	131	160	175	200	215	235	250	270	289	309	330	
30	Q [m ³ ·h ⁻¹]	131	160	175	200	215	235	250	270	289	309	330
	T ₃ [°C]	53	51	51	50	50	50	50	49	49	49	49
	P _e [kW]	1,6	2	2	2,2	2,4	2,6	2,7	2,9	3,1	3,3	3,5
	P _m [kW]	2,2	2,2	3	3	3	4	4	4	4	4	5,5
	n [min ⁻¹]	2312	2688	2890	3225	3429	3692	3891	4150	4409	4668	4957
	n _m [min ⁻¹]	2880	2880	2890	2890	2890	2905	2905	2905	2905	2905	2925
	Elmotor	90-2	90-2	100-2	100-2	100-2	112-2	112-2	112-2	112-2	112-2	132-2
	i	106/132	140/150	125/125	125/112	140/118	150/118	150/112	160/112	170/112	180/112	200/118
	X	1/XPZ	1/XPZ	1/XPA	1/XPA	1/XPA	1/XPA	1/XPA	1/XPA	1/XPA	1/XPA	1/XPA
	L _{mA} [dB]	69/83	70/88	71/89	71/89	72/91	73/92	73/92	74/93	75/94	76/96	77/97
40	Q [m ³ ·h ⁻¹]	126	155	171	196	212	232	247	267	286	306	325
	T ₃ [°C]	65	63	62	61	61	60	60	59	60	59	59
	P _e [kW]	2,1	2,4	2,6	2,9	3,1	3,4	3,6	3,8	4	4,3	4,6
	P _m [kW]	3	3	4	4	4	5,5	5,5	5,5	5,5	5,5	5,5
	n [min ⁻¹]	2312	2697	2905	3242	3447	3718	3917	4178	4440	4700	4957
	n _m [min ⁻¹]	2890	2890	2905	2905	2905	2925	2925	2925	2925	2925	2925
	Elmotor	100-2	100-2	112-2	112-2	112-2	132-2	132-2	132-2	132-2	132-2	132-2
	i	112/140	140/150	125/125	125/112	140/118	150/118	150/112	160/112	170/112	180/112	200/118
	X	1/XPZ	1/XPA	1/XPA	1/XPA	1/XPA	1/XPA	1/XPA	1/XPA	1/XPA	1/XPA	1/XPA
	L _{mA} [dB]	70/83	71/89	71/90	72/91	73/92	73/92	74/93	75/94	76/96	77/97	78/98
50	Q [m ³ ·h ⁻¹]	121	151	166	193	209	228	243	262	283	302	321
	T ₃ [°C]	79	75	74	72	72	71	71	70	70	69	69
	P _e [kW]	2,6	3	3,3	3,7	3,9	4,2	4,4	4,7	5	5,4	5,7
	P _m [kW]	4	4	4	5,5	5,5	5,5	5,5	5,5	7,5	7,5	7,5
	n [min ⁻¹]	2324	2711	2905	3264	3470	3718	3917	4178	4447	4708	4957
	n _m [min ⁻¹]	2905	2905	2905	2925	2925	2925	2925	2925	2930	2930	2925
	Elmotor	112-2	112-2	112-2	132-2	132-2	132-2	132-2	132-2	132-2	132-2	132-2
	i	112/140	140/150	125/125	125/112	140/118	150/118	150/112	160/112	170/112	180/112	200/118
	X	1/XPA	1/XPA	1/XPA	1/XPA	1/XPA	1/XPA	1/XPA	1/XPA	1/XPA	1/XPA	1/XPA
	L _{mA} [dB]	71/83	71/90	72/91	73/92	74/93	74/93	75/94	76/96	76/97	77/98	78/99
60	Q [m ³ ·h ⁻¹]	118	140	164	190	205	224	239	259	279	299	319
	T ₃ [°C]	93	89	86	84	83	82	82	80	80	79	79
	P _e [kW]	3,1	4	3,9	4,4	4,7	5	5,3	5,7	6	6,4	6,8
	P _m [kW]	4	5,5	5,5	5,5	5,5	7,5	7,5	7,5	7,5	7,5	11
	n [min ⁻¹]	2324	2614	2925	3264	3470	3724	3924	4185	4447	4708	4983
	n _m [min ⁻¹]	2905	2925	2925	2925	2925	2930	2930	2930	2930	2930	2940
	Elmotor	112-2	132-2	132-2	132-2	132-2	132-2	132-2	132-2	132-2	132-2	160-2
	i	112/140	118/132	125/125	125/112	140/118	150/118	150/112	160/112	170/112	180/112	200/118
	X	1/XPA	1/XPA	1/XPA	1/XPA	1/XPA	1/XPA	1/XPA	1/XPA	1/XPA	1/XPA	2/XPZ
	L _{mA} [dB]	72/89	72/91	73/92	73/94	74/94	74/95	75/95	76/96	77/98	78/98	79/100
70	Q [m ³ ·h ⁻¹]	116	137	160	187	202	221	236	257	277	297	335
	T ₃ [°C]	107	103	99	96	95	93	93	91	91	90	89
	P _e [kW]	3,63	4	4,6	5,1	5,4	5,9	6,2	6,6	7	7,5	8,5
	P _m [kW]	5,5	5,5	5,5	7,5	7,5	7,5	7,5	11	11	11	11
	n [min ⁻¹]	2340	2614	2925	3270	3476	3724	3924	4200	4462	4725	5250
	n _m [min ⁻¹]	2925	2925	2925	2930	2930	2930	2930	2940	2940	2940	2940
	Elmotor	132-2	132-2	132-2	132-2	132-2	132-2	232-2	160-2	160-2	160-2	160-2
	i	112/140	118/132	125/125	125/112	140/118	150/118	150/112	160/112	170/112	180/112	200/112
	X	1/XPA	1/XPA	1/XPA	1/XPA	1/XPA	1/XPA	2/XPZ	2/XPZ	2/XPZ	2/XPZ	2/XPZ
	L _{mA} [dB]	72/90	73/92	73/93	74/94	74/95	75/96	76/97	77/98	78/98	79/99	80/100
80	Q [m ³ ·h ⁻¹]	110	131	158	184	200	219	234	254	274	294	333
	T ₃ [°C]	123	117	112	108	107	104	104	102	102	100	99
	P _e [kW]	4,1	5	5,2	5,9	6,2	6,7	7	7,6	8	8,5	9,5
	P _m [kW]	5,5	5,5	7,5	7,5	7,5	11	11	11	11	11	11
	n [min ⁻¹]	2301	2574	2930	3277	3476	3737	3937	4200	4462	4725	5250
	n _m [min ⁻¹]	2925	2925	2930	2930	2930	2940	2940	2940	2940	2940	2940
	Elmotor	132-2	132-2	132-2	132-2	132-2	160-2	160-2	160-2	160-2	160-2	160-2
	i	118/150	132/150	132/132	132/118	140/118	150/118	150/112	160/112	170/112	180/112	200/112
	X	1/XPA	1/XPA	1/XPA	1/XPA	1/XPA	2/XPZ	2/XPZ	2/XPZ	2/XPZ	2/XPZ	2/XPZ
	L _{mA} [dB]	73/92	73/93	74/95	74/95	75/96	76/97	77/98	78/99	79/100	80/101	81/102
90	Q [m ³ ·h ⁻¹]	106	129	156	183	198	217	232	252	272		
	T ₃ [°C]	139	131	124	120	119	116	116	113	113		
	P _e [kW]	4,6	5	5,9	6,6	7	7,5	7,9	8,5	9		
	P _m [kW]	5,5	7,5	7,5	11	11	11	11	11	11		
	n [min ⁻¹]	2285	2578	2930	3288	3488	3737	3937	4200	4462		
	n _m [min ⁻¹]	2925	2930	2930	2940	2940	2940	2940	2940	2940		
	Elmotor	132-2	132-2	132-2	160-2	160-2	160-2	160-2	160-2	160-2		
	i	125/160	132/150	132/132	132/118	140/118	150/118	150/112	160/112	170/112		
	X	1/XPA	1/XPA	1/XPA	2/XPZ	2/XPZ	2/XPZ	2/XPZ	2/XPZ	2/XPZ		
	L _{mA} [dB]	73/93	74/95	74/95	75/96	76/97	77/98	78/99	79/100	80/102		
100	Q [m ³ ·h ⁻¹]			154	181	196	215	230	250	270		
	T ₃ [°C]			137	132	131	127	127	124	124		
	P _e [kW]			6,6	7,3	7,7	8,4	8,8	9,4	10		
	P _m [kW]			11	11	11	11	11	11	15		
	n [min ⁻¹]			2940	3288	3488	3737	3937	4200	4462		
	n _m [min ⁻¹]			2940	2940	2940	2940	2940	2940	2940		
	Elmotor			160-2	160-2	160-2	160-2	160-2	160-2	160-2		
	i			132/132	132/118	140/118	150/118	150/112	160/112	170/112		
	X			2/XPZ	2/XPZ	2/XPZ	2/XPZ	2/XPZ	2/XPZ	2/XPZ		
	L _{mA} [dB]			75/96	76/97	77/98	78/99	79/100	80/101	81/102		

Δp [kPa]		DT 30/42 DN 65							DT 30/72 DN 80			
30	Q [m ³ ·h ⁻¹]	222	260	297	340	362	385	401	424	453	482	511
	T ₃ [°C]	50	50	49	49	49	49	49	48	48	48	48
	P _e [kW]	2,5	2,8	3,2	3,6	3,8	4	4,1	4,4	4,7	5	5,3
	P _m [kW]	3	4	4	5,5	5,5	5,5	5,5	5,5	5,5	5,5	7,5
	n [min ⁻¹]	2550	2905	3247	3648	3854	4061	4210	4432	4698	4972	5239
	n _m [min ⁻¹]	2890	2905	2905	2925	2925	2925	2925	2925	2925	2930	2930
	Elmotor	100-2	112-2	112-2	132-2	132-2	132-2	132-2	132-2	132-2	132-2	132-2
	i	150/170	170/170	190/170	212/170	224/170	236/170	190/132	200/132	212/132	224/132	236/132
	X	1/XPA	1/XPA	1/XPA	1/XPA	1/XPA	1/XPA	1/XPA	1/XPA	1/XPA	1/XPA	1/XPA
	L _{mA} [dB]	70/91	71/92	71/92	72/92	73/93	74/94	74/94	76/95	77/97	77/98	80/100
40	Q [m ³ ·h ⁻¹]	217	256	293	334	356	379	397	419	447	478	506
	T ₃ [°C]	62	60	60	59	59	58	59	58	58	58	58
	P _e [kW]	3,3	3,8	4,2	4,8	5	5,3	5,5	5,8	6,2	6,6	7
	P _m [kW]	4	5,5	5,5	7,5	7,5	7,5	7,5	7,5	7,5	11	11
	n [min ⁻¹]	2563	2925	3269	3654	3860	4068	4217	4439	4706	4989	5256
	n _m [min ⁻¹]	2905	2925	2925	2930	2930	2930	2930	2930	2930	2940	2940
	Elmotor	112-2	132-2	132-2	132-2	132-2	132-2	132-2	132-2	132-2	160-2	160-2
	i	150/170	170/170	190/170	212/170	224/170	236/170	190/132	200/132	212/132	224/132	236/132
	X	1/XPA	1/XPA	1/XPA	1/XPA	1/XPA	1/XPA	1/XPA	1/XPA	1/XPA	1/XPA	1/XPA
	L _{mA} [dB]	71/91	71/92	71/92	72/92	73/93	73/94	75/95	76/96	77/97	78/98	81/101
50	Q [m ³ ·h ⁻¹]	213	250	288	329	351	375	391	415	444	472	501
	T ₃ [°C]	73	72	70	69	69	68	69	68	68	67	67
	P _e [kW]	4,1	4,7	5,3	5,9	6,2	6,6	6,9	7,2	7,7	8,2	8,7
	P _m [kW]	5,5	5,5	7,5	7,5	7,5	11	11	11	11	11	11
	n [min ⁻¹]	2580	2925	3275	3654	3860	4081	4232	4455	4722	4989	5256
	n _m [min ⁻¹]	2925	2925	2930	2930	2930	2940	2940	2940	2940	2940	2940
	Elmotor	132-2	132-2	132-2	132-2	132-2	160-2	160-2	160-2	160-2	160-2	160-2
	i	150/170	170/170	190/170	212/170	224/170	236/170	190/132	200/132	212/132	224/132	236/132
	X	1/XPA	1/XPA	1/XPA	1/XPA	1/XPA	1/XPA	1/XPA	1/XPA	1/XPA	1/XPA	1/XPA
	L _{mA} [dB]	72/92	72/93	73/94	73/94	74/95	74/95	76/97	78/98	79/99	80/100	82/102
60	Q [m ³ ·h ⁻¹]	208	246	283	325	348	370	386	410	439	468	497
	T ₃ [°C]	86	83	81	80	80	79	79	78	78	77	77
	P _e [kW]	4,9	5,6	6,3	7,1	7,5	7,9	8,2	8,6	9,2	9,8	10,3
	P _m [kW]	7,5	7,5	7,5	11	11	11	11	11	11	15	15
	n [min ⁻¹]	2585	2930	3275	3666	3874	4081	4232	4455	4722	4989	5256
	n _m [min ⁻¹]	2930	2930	2930	2940	2940	2940	2940	2940	2940	2940	2940
	Elmotor	132-2	132-2	132-2	160-2	160-2	160-2	160-2	160-2	160-2	160-2	160-2
	i	150/170	170/170	190/170	212/170	224/170	236/170	190/132	200/132	212/132	224/132	236/132
	X	1/XPA	1/XPA	1/XPA	1/XPA	1/XPA	1/XPA	1/XPA	1/XPA	1/XPA	1/XPA	1/XPA
	L _{mA} [dB]	73/94	73/95	74/95	75/96	76/96	77/97	77/98	78/98	79/99	80/101	82/102
70	Q [m ³ ·h ⁻¹]	204	243	280	321	344	366	382	406	435	464	493
	T ₃ [°C]	98	95	92	91	91	89	89	88	88	87	87
	P _e [kW]	5,7	6,5	7,3	8,2	8,7	9,2	9,5	10,1	10,7	11,3	12
	P _m [kW]	7,5	11	11	11	11	11	11	15	15	15	15
	n [min ⁻¹]	2585	2940	3286	3666	3874	4081	4232	4455	4722	4989	5256
	n _m [min ⁻¹]	2930	2940	2940	2940	2940	2940	2940	2940	2940	2940	2940
	Elmotor	132-2	160-2	160-2	160-2	160-2	160-2	160-2	160-2	160-2	160-2	160-2
	i	150/170	170/170	190/170	212/170	224/170	236/170	190/132	200/132	212/132	224/132	236/132
	X	1/XPA	1/XPA	1/XPA	1/XPA	1/XPA	1/XPA	1/XPA	1/XPA	1/XPA	2/XPA	2/XPA
	L _{mA} [dB]	74/94	75/96	76/96	76/97	77/97	77/98	78/98	79/99	80/100	81/101	82/102
80	Q [m ³ ·h ⁻¹]	201	239	276	318	340	362	379	403	432	460	489
	T ₃ [°C]	111	107	104	102	101	100	100	98	98	97	97
	P _e [kW]	6,6	7,5	8,4	9,4	9,9	10,5	10,9	11,5	12,2	12,9	13,6
	P _m [kW]	11	11	11	11	15	15	15	15	15	15	18,5
	n [min ⁻¹]	2594	2940	3286	3666	3874	4081	4232	4455	4722	4989	5256
	n _m [min ⁻¹]	2940	2940	2940	2940	2940	2940	2940	2940	2940	2940	2940
	Elmotor	160-2	160-2	160-2	160-2	160-2	160-2	160-2	160-2	160-2	160-2	160-2
	i	150/170	170/170	190/170	212/170	224/170	236/170	190/132	200/132	212/132	224/132	236/132
	X	1/XPA	1/XPA	1/XPA	1/XPA	1/XPA	1/XPA	1/XPA	2/XPA	2/XPA	2/XPA	2/XPA
	L _{mA} [dB]	74/95	75/96	76/97	77/97	78/98	78/99	79/99	80/100	81/101	82/103	83/104
90	Q [m ³ ·h ⁻¹]	198	236	273	314	337	359	376	400	428	457	486
	T ₃ [°C]	124	119	115	113	112	110	111	109	108	107	106
	P _e [kW]	7,4	8,4	9,4	10,5	11,1	11,7	12,2	12,9	13,7	14,5	15,3
	P _m [kW]	11	11	11	15	15	15	15	15	18,5	18,5	18,5
	n [min ⁻¹]	2594	2940	3286	3666	3874	4081	4232	4455	4722	4989	5256
	n _m [min ⁻¹]	2940	2940	2940	2940	2940	2940	2940	2940	2940	2940	2940
	Elmotor	160-2	160-2	160-2	160-2	160-2	160-2	160-2	160-2	160-2	160-2	160-2
	i	150/170	170/170	190/170	212/170	224/170	236/170	190/132	200/132	212/132	224/132	236/132
	X	1/XPA	1/XPA	1/XPA	1/XPA	1/XPA	1/XPA	1/XPA	2/XPA	2/XPA	2/XPA	2/XPA
	L _{mA} [dB]	74/96	76/97	77/98	78/98	78/99	79/100	80/101	81/102	82/103	82/104	83/105
100	Q [m ³ ·h ⁻¹]	195	233	270	312	334	356	373	397	426		
	T ₃ [°C]	137	131	127	124	123	131	121	119	118		
	P _e [kW]	8,2	9,3	10,4	11,7	12,4	13	13,5	14,3	15,2		
	P _m [kW]	11	11	15	15	15	18,5	18,5	18,5	18,5		
	n [min ⁻¹]	2594	2940	3286	3666	3874	4081	4232	4455	4722		
	n _m [min ⁻¹]	2940	2940	2940	2940	2940	2940	2940	2940	2940		
	Elmotor	160-2	160-2	160-2	160-2	160-2	160-2	160-2	160-2	160-2		
	i	150/170	170/170	190/170	212/170	224/170	236/170	190/132	200/132	212/132		
	X	1/XPA	1/XPA	1/XPA	1/XPA	1/XPA	1/XPA	2/XPA	2/XPA	2/XPA		
	L _{mA} [dB]	74/95	76/96	77/98	78/99	79/99	79/100	80/101	80/102	82/104		

Δp [kPa]		DT 40/72 DN 80										
		264	312	362	413	469	499	530	551	584	625	664
30	Q [m ³ ·h ⁻¹]	264	312	362	413	469	499	530	551	584	625	664
	T ₃ [°C]	51	50	50	49	49	49	49	49	49	49	49
	P _e [kW]	3	3,4	4	4,4	5	5,3	5,6	5,9	6,2	6,7	7,2
	P _m [kW]	4	5,5	5,5	5,5	7,5	7,5	7,5	7,5	7,5	11	11
	n [min ⁻¹]	2256	2581	2925	3269	3654	3861	4068	4217	4439	4722	4989
	n _m [min ⁻¹]	2905	2925	2925	2925	2930	2930	2930	2930	2930	2940	2940
	Elmotor	112-2	132-2	132-2	132-2	132-2	132-2	132-2	132-2	132-2	160-2	160-2
	i	132/170	150/170	170/170	190/170	212/170	224/170	236/170	190/132	200/132	212/132	224/132
	X	1/XPA	1/XPA	1/XPA	1/XPA	1/XPA	1/XPA	1/XPA	1/XPA	1/XPA	1/XPA	1/XPA
	L _{mA} [dB]	71/92	71/92	72/92	73/93	74/94	74/94	76/95	77/97	77/98	80/100	81/102
40	Q [m ³ ·h ⁻¹]	258	304	355	406	463	493	524	546	578	617	656
	T ₃ [°C]	63	61	60	60	59	59	59	59	59	59	59
	P _e [kW]	4	4,5	5,2	5,8	6,6	7	7,4	7,7	8,2	8,7	9,3
	P _m [kW]	5,5	5,5	7,5	7,5	11	11	11	11	11	11	11
	n [min ⁻¹]	2271	2581	2930	3275	3666	3874	4081	4232	4455	4722	4989
	n _m [min ⁻¹]	2925	2925	2930	2930	2940	2940	2940	2940	2940	2940	2940
	Elmotor	132-2	132-2	132-2	132-2	160-2	160-2	160-2	160-2	160-2	160-2	160-2
	i	132/170	150/170	170/170	190/170	212/170	224/170	236/170	190/132	200/132	212/132	224/132
	X	1/XPA	1/XPA	1/XPA	1/XPA	1/XPA	1/XPA	1/XPA	1/XPA	1/XPA	1/XPA	1/XPA
	L _{mA} [dB]	71/92	71/92	72/92	73/93	73/94	75/95	76/96	77/97	78/98	81/101	82/102
50	Q [m ³ ·h ⁻¹]	252	297	348	400	456	487	517	539	572	611	650
	T ₃ [°C]	75	73	71	70	69	69	69	69	68	68	68
	P _e [kW]	5	5,6	6,4	7,3	8,1	8,6	9,1	9,5	10,1	10,7	11,4
	P _m [kW]	7,5	7,5	7,5	11	11	11	11	11	15	15	15
	n [min ⁻¹]	2275	2585	2930	3286	3666	3874	4081	4232	4455	4722	4989
	n _m [min ⁻¹]	2930	2930	2930	2940	2940	2940	2940	2940	2940	2940	2940
	Elmotor	132-2	132-2	132-2	160-2	160-2	160-2	160-2	160-2	160-2	160-2	160-2
	i	132/170	150/170	170/170	190/170	212/170	224/170	236/170	190/132	200/132	212/132	224/132
	X	1/XPA	1/XPA	1/XPA	1/XPA	1/XPA	1/XPA	1/XPA	1/XPA	1/XPA	1/XPA	2/XPA
	L _{mA} [dB]	72/93	73/94	73/94	74/95	74/95	76/97	78/98	79/99	80/100	82/102	83/103
60	Q [m ³ ·h ⁻¹]	245	293	344	395	450	481	511	533	566	605	644
	T ₃ [°C]	87	84	82	81	79	79	79	79	78	78	78
	P _e [kW]	6	6,8	7,7	8,7	9,7	10,3	10,9	11,3	12	12,7	13,5
	P _m [kW]	7,5	11	11	11	15	15	15	15	15	15	18,5
	n [min ⁻¹]	2275	2594	2940	3286	3666	3874	4081	4232	4455	4722	4989
	n _m [min ⁻¹]	2930	2940	2940	2940	2940	2940	2940	2940	2940	2940	2940
	Elmotor	132-2	160-2	160-2	160-2	160-2	1650-2	160-2	160-2	160-2	160-2	160-2
	i	132/170	150/170	170/170	190/170	212/170	224/170	236/170	190/132	200/132	212/132	224/132
	X	1/XPA	1/XPA	1/XPA	1/XPA	1/XPA	1/XPA	1/XPA	1/XPA	2/XPA	2/XPA	2/XPA
	L _{mA} [dB]	73/95	74/95	75/96	76/96	77/97	77/98	78/98	79/99	80/101	82/101	83/103
70	Q [m ³ ·h ⁻¹]	241	287	339	390	445	476	506	529	561	600	640
	T ₃ [°C]	100	96	93	91	90	90	89	89	88	88	87
	P _e [kW]	7	7,9	9	10,1	11,3	12	12,6	13,1	13,9	14,8	15,7
	P _m [kW]	11	11	11	15	15	15	15	15	18,5	18,5	18,5
	n [min ⁻¹]	2283	2594	2940	3286	3666	3874	4081	4232	4455	4722	4989
	n _m [min ⁻¹]	2940	2940	2940	2940	2940	2940	2940	2940	2940	2940	2940
	Elmotor	160-2	160-2	160-2	160-2	160-2	160-2	160-2	160-2	160-2	160-2	160-2
	i	132/170	150/170	170/170	190/170	212/170	224/170	236/170	190/132	200/132	212/132	224/132
	X	1/XPA	1/XPA	1/XPA	1/XPA	1/XPA	1/XPA	1/XPA	2/XPA	2/XPA	2/XPA	2/XPA
	L _{mA} [dB]	75/96	76/96	76/97	77/97	77/98	78/98	79/99	80/100	81/101	82/102	84/104
80	Q [m ³ ·h ⁻¹]	237	283	334	385	441	472	502	524	557	597	637
	T ₃ [°C]	113	108	105	102	101	101	99	99	98	97	97
	P _e [kW]	7,9	9	10,2	11,5	12,8	13,6	14,4	14,9	15,8	16,8	17,9
	P _m [kW]	11	11	15	15	15	18,5	18,5	18,5	18,5	22	22
	n [min ⁻¹]	2283	2594	2940	3286	3666	3874	4081	4232	4455	4730	4998
	n _m [min ⁻¹]	2940	2940	2940	2940	2940	2940	2940	2940	2940	2945	2945
	Elmotor	160-2	160-2	160-2	160-2	160-2	160-2	160-2	160-2	160-2	180-2	180-2
	i	132/170	150/170	170/170	190/170	212/170	224/170	236/170	190/132	200/132	212/132	224/132
	X	2/XPA	2/XPA	2/XPA	2/XPA	2/XPA	2/XPA	2/XPA	2/XPA	2/XPA	2/XPA	2/XPA
	L _{mA} [dB]	75/96	76/97	77/97	78/98	78/99	79/99	80/100	81/101	82/103	83/104	84/105
90	Q [m ³ ·h ⁻¹]	233	279	330	381	437	468	499	522	554	594	
	T ₃ [°C]	126	121	116	114	111	111	109	110	108	107	
	P _e [kW]	8,9	10,1	11,5	12,9	14,4	15,3	16,2	16,8	17,7	18,9	
	P _m [kW]	11	15	15	15	18,5	18,5	22	22	22	22	
	n [min ⁻¹]	2283	2594	2940	3286	3666	3874	4088	4239	4462	4730	
	n _m [min ⁻¹]	2940	2940	2940	2940	2940	2940	2945	2945	2945	2945	
	Elmotor	160-2	160-2	160-2	160-2	160-2	160-2	180-2	180-2	180-2	180-2	
	i	132/170	150/170	170/170	190/170	212/170	224/170	236/170	190/132	200/132	212/132	
	X	2/XPA	2/XPA	2/XPA	2/XPA	2/XPA	2/XPA	2/XPA	2/XPA	2/XPA	2/XPA	
	L _{mA} [dB]	76/97	77/98	78/98	78/99	79/100	80/101	81/102	82/103	82/104	84/105	
100	Q [m ³ ·h ⁻¹]											
	T ₃ [°C]											
	P _e [kW]											
	P _m [kW]											
	n [min ⁻¹]											
	n _m [min ⁻¹]											
	Elmotor											
	i											
	X											
	L _{mA} [dB]											

DT 50/72

DT 50/102



Δp [kPa]		DT 50/72 DN 80						DT 50/102 DN 100				
		482	558	598	635	673	719	777	829	880	953	1011
30	Q [m ³ ·h ⁻¹]	482	558	598	635	673	719	777	829	880	953	1011
	T ₃ [°C]	51	51	51	51	51	51	49	49	49	49	49
	P _e [kW]	5,4	6,2	6,7	7,1	7,6	8,1	8,3	8,9	9,4	10,3	11
	P _m [kW]	7,5	7,5	11	11	11	11	11	11	11	15	15
	n [min ⁻¹]	2585	2930	3118	3285	3459	3666	3920	4155	4390	4722	4989
	n _m [min ⁻¹]	2930	2930	2940	2940	2940	2940	2940	2940	2940	2940	2940
	Elmotor	132-2	132-2	160-2	160-2	160-2	160-2	160-2	160-2	160-2	160-2	160-2
	i	150/170	170/170	180/170	190/170	200/170	212/170	200/150	212/150	224/150	212/132	224/132
	X	2/XPA	2/XPA	2/XPA	2/XPA	2/XPA	2/XPA	2/XPA	2/XPA	2/XPA	2/XPA	2/XPA
	L _{mA} [dB]	67/88	68/90	69/91	69/91	70/92	70/92	71/92	71/92	72/93	73/94	74/95
40	Q [m ³ ·h ⁻¹]	474	550	588	626	664	709	767	819	870	943	1002
	T ₃ [°C]	62	61	61	61	61	61	58	58	58	58	58
	P _e [kW]	7,1	8,1	8,7	9,2	9,8	10,5	10,8	11,5	12,3	13,3	14,2
	P _m [kW]	11	11	11	11	15	15	15	15	15	18,5	18,5
	n [min ⁻¹]	2594	2940	3113	3286	3459	3666	3920	4155	4390	4722	4989
	n _m [min ⁻¹]	2940	2940	2940	2940	2940	2940	2940	2940	2940	2940	2940
	Elmotor	160-2	160-2	160-2	160-2	160-2	160-2	160-2	160-2	160-2	160-2	160-2
	i	150/170	170/170	180/170	190/170	200/170	212/170	200/150	212/150	224/150	212/132	224/132
	X	2/XPA	2/XPA	2/XPA	2/XPA	2/XPA	2/XPA	2/XPA	2/XPA	2/XPA	2/XPA	2/XPA
	L _{mA} [dB]	67/89	68/91	70/92	70/93	71/93	71/93	72/94	72/94	73/95	74/95	75/96
50	Q [m ³ ·h ⁻¹]	465	541	579	617	655	701	759	810	862	937	995
	T ₃ [°C]	73	72	72	71	71	71	68	68	68	68	68
	P _e [kW]	8,8	10,0	10,7	11,3	12,0	12,8	13,3	14,2	15,1	16,4	17,5
	P _m [kW]	11	15	15	15	15	15	18,5	18,5	18,5	22	22
	n [min ⁻¹]	2594	2940	3113	3286	3459	3666	3920	4155	4390	4730	4998
	n _m [min ⁻¹]	2940	2940	2940	2940	2940	2940	2940	2940	2940	2945	2945
	Elmotor	160-2	160-2	160-2	160-2	160-2	160-2	160-2	160-2	160-2	180-2	180-2
	i	150/170	170/170	180/170	190/170	200/170	212/170	200/150	212/150	224/150	212/132	224/132
	X	2/XPA	2/XPA	2/XPA	2/XPA	2/XPA	2/XPA	2/XPA	2/XPA	2/XPA	2/XPA	2/XPA
	L _{mA} [dB]	68/91	69/93	70/94	71/94	71/95	72/95	73/95	73/95	74/96	75/96	75/97
60	Q [m ³ ·h ⁻¹]	458	534	572	610	648	694	752	805	857	931	990
	T ₃ [°C]	84	83	82	82	81	81	78	78	77	77	77
	P _e [kW]	10,4	11,9	12,5	13,4	14,2	15,1	15,9	16,9	18	19,5	20,7
	P _m [kW]	15	15	15	18,5	18,5	18,5	18,5	22	22	30	30
	n [min ⁻¹]	2594	2940	3113	3286	3459	3666	3920	4162	4398	4738	5006
	n _m [min ⁻¹]	2940	2940	2940	2940	2940	2940	2940	2945	2945	2950	2950
	Elmotor	160-2	160-2	160-2	160-2	160-2	160-2	160-2	180-2	180-2	200-2	200-2
	i	150/170	170/170	180/170	190/170	200/170	212/170	200/150	212/150	224/150	212/132	224/132
	X	2/XPA	2/XPA	2/XPA	2/XPA	2/XPA	2/XPA	2/XPA	2/XPA	2/XPA	2/XPA	2/XPA
	L _{mA} [dB]	68/92	69/93	71/95	71/95	72/95	73/95	74/96	74/96	75/96	76/96	76/97
70	Q [m ³ ·h ⁻¹]	452	528	566	604	643	689	747	800	852	925	984
	T ₃ [°C]	95	94	93	92	92	91	88	87	87	87	87
	P _e [kW]	12,1	13,8	14,7	15,5	16,5	17,5	18,5	19,7	20,9	22,6	24
	P _m [kW]	15	18,5	18,5	22	22	22	22	30	30	30	30
	n [min ⁻¹]	2594	2940	3113	3286	3465	3673	3927	4169	4405	4738	5006
	n _m [min ⁻¹]	2940	2940	2940	2940	2945	2945	2945	2950	2950	2950	2950
	Elmotor	160-2	160-2	160-2	160-2	180-2	180-2	180-2	200-2	200-2	200-2	200-2
	i	150/170	170/170	180/170	190/170	200/170	212/170	200/150	212/150	224/150	212/132	224/132
	X	2/XPA	2/XPA	2/XPA	2/XPA	2/XPA	2/XPA	2/XPA	2/XPA	2/XPA	2/XPA	2/XPA
	L _{mA} [dB]	68/92	69/93	71/95	71/95	72/96	73/96	73/96	74/96	75/97	76/97	76/98
80	Q [m ³ ·h ⁻¹]	446	522	562	600	638	685	743	795	847	920	979
	T ₃ [°C]	107	105	104	103	102	102	98	97	97	96	96
	P _e [kW]	13,8	15,7	16,7	17,7	18,7	20,0	21,1	22,4	23,8	25,7	27,3
	P _m [kW]	18,5	18,5	22	22	22	30	30	30	30	30	37
	n [min ⁻¹]	2594	2940	3118	3291	3465	3679	3933	4169	4405	4738	5006
	n _m [min ⁻¹]	2940	2940	2945	2945	2945	2950	2950	2950	2950	2950	2950
	Elmotor	160-2	160-2	160-2	180-2	180-2	200-2	200-2	200-2	200-2	200-2	200-2
	i	150/170	170/170	180/170	190/170	200/170	212/170	200/150	212/150	224/150	212/132	224/132
	X	2/XPA	2/XPA	2/XPA	2/XPA	2/XPA	2/XPA	2/XPA	2/XPA	2/XPA	3/XPA	3/XPA
	L _{mA} [dB]	69/93	70/94	71/95	72/96	72/96	73/96	74/96	74/97	75/97	77/98	78/98
90	Q [m ³ ·h ⁻¹]	441	519	557	596	635	680	728	774	842	894	974
	T ₃ [°C]	119	116	115	114	113	112	108	107	107	106	106
	P _e [kW]	15,4	17,6	18,7	19,9	21,0	22,3	23,3	24,7	26,6	28,2	30,6
	P _m [kW]	18,5	22	22	30	30	30	30	30	37	37	37
	n [min ⁻¹]	2594	2945	3118	3297	3471	3679	3887	4095	4405	4641	5006
	n _m [min ⁻¹]	2940	2945	2945	2950	2950	2950	2950	2950	2950	2950	2950
	Elmotor	160-2	180-2	180-2	200-2	200-2	200-2	200-2	200-2	200-2	200-2	200-2
	i	150/170	170/170	180/170	190/170	200/170	212/170	224/170	236/170	224/150	236/150	224/132
	X	2/XPA	2/XPA	2/XPA	3/XPA	3/XPA	2/XPA	2/XPA	2/XPA	3/XPA	3/XPA	3/XPA
	L _{mA} [dB]	69/93	70/94	71/95	72/96	73/96	74/97	74/97	75/97	76/98	77/99	78/100
100	Q [m ³ ·h ⁻¹]	438	516	554	592	631	676	724	769	838	890	971
	T ₃ [°C]	130	127	126	124	123	122	118	118	117	116	117
	P _e [kW]	17,1	19,6	20,8	22,0	23,2	24,7	25,9	27,3	29,5	31,2	34
	P _m [kW]	22	30	30	30	30	30	30	37	37	37	45
	n [min ⁻¹]	2599	2950	3124	3297	3471	3679	3887	4095	4405	4641	5015
	n _m [min ⁻¹]	2945	2950	2950	2950	2950	2950	2950	2950	2950	2950	2955
	Elmotor	180-2	200-2	200-2	200-2	200-2	200-2	200-2	200-2	200-2	200-2	200-2
	i	150/170	170/170	180/170	190/170	200/170	212/170	224/170	236/170	224/150	236/150	224/132
	X	2/XPA	2/XPA	3/XPA	3/XPA	3/XPA	3/XPA	2/XPA	3/XPA	3/XPA	3/XPA	4/XPA
	L _{mA} [dB]	70/94	72/96	72/96	73/97	73/97	74/97	75/97	76/97	77/98	78/99	79/101

CZ Dmychadlová soustrojí pro přetlak

UK Blower packages for pressure

D Gebläseaggregate für Überdruck

RU Нагнетательные агрегаты

DT 60/102



Δp [kPa]		DT 60/102 DN 100										
30	Q [m ³ ·h ⁻¹]	654	699	742	787	840	893	952	1007	1069	1138	1215
	T ₃ [°C]	50	50	50	50	49	50	50	50	50	51	51
	P _e [kW]	7,1	8	8	8,5	9,1	9,7	10,4	11,3	12	12,6	13,5
	P _m [kW]	11	11	11	11	11	15	15	15	15	15	18,5
	n [min ⁻¹]	2634	2791	2940	3098	3282	3467	3675	3868	4081	4324	4594
	n _m [min ⁻¹]	2940	2940	2940	2940	2940	2940	2940	2940	2940	2940	2940
	Elmotor	160-2	160-2	160-2	160-2	160-2	160-2	160-2	160-2	160-2	160-2	160-2
	i	224/250	224/236	224/224	236/224	250/224	250/212	250/200	250/190	236/170	250/170	250/160
	X	2/XPA	2/XPA	2/XPA	2/XPA	2/XPA	2/XPA	2/XPA	2/XPA	2/XPA	2/XPA	2/XPA
	L _{MA} [dB]	66/91	66/90	67/91	68/92	70/93	70/93	71/93	72/94	73/95	72/96	74/96
	40	Q [m ³ ·h ⁻¹]	641	687	730	775	828	881	940	996	1057	1128
T ₃ [°C]		61	61	61	60	60	60	60	60	60	60	60
P _e [kW]		9,3	10	10,5	11,1	11,8	12,6	13,5	14,6	15,4	16,3	17,3
P _m [kW]		11	15	15	15	15	15	18,5	18,5	18,5	22	22
n [min ⁻¹]		2634	2791	2940	3098	3282	3467	3675	3868	4081	4331	4602
n _m [min ⁻¹]		2940	2940	2940	2940	2940	2940	2940	2940	2940	2945	2945
Elmotor		160-2	160-2	160-2	160-2	160-2	160-2	160-2	160-2	160-2	180-2	180-2
i		224/250	224/236	224/224	236/224	250/224	250/212	250/200	250/190	250/180	250/170	250/160
X		2/XPA	2/XPA	2/XPA	2/XPA	2/XPA	2/XPA	2/XPA	2/XPA	2/XPA	2/XPA	2/XPA
L _{MA} [dB]		68/92	68/92	68/93	69/94	70/94	71/94	71/95	72/96	73/96	72/96	74/97
50		Q [m ³ ·h ⁻¹]	631	676	719	765	818	871	932	988	1052	1121
	T ₃ [°C]	71	71	71	71	70	70	70	70	70	70	70
	P _e [kW]	11,5	12,3	13	13,7	14,6	15,6	16,6	17,9	19	20	21,2
	P _m [kW]	15	15	18,5	18,5	18,5	18,5	22	22	22	30	30
	n [min ⁻¹]	2634	2791	2940	3095	3282	3467	3681	3875	4097	4338	4609
	n _m [min ⁻¹]	2940	2940	2940	2940	2940	2940	2945	2945	2950	2950	2950
	Elmotor	160-2	160-2	160-2	160-2	160-2	160-2	180-2	180-2	180-2	200-2	200-2
	i	224/250	224/236	224/224	236/224	250/224	250/212	250/200	250/190	250/180	250/170	250/160
	X	2/XPA	2/XPA	2/XPA	2/XPA	2/XPA	2/XPA	2/XPA	2/XPA	2/XPA	2/XPA	2/XPA
	L _{MA} [dB]	68/92	68/93	69/93	70/94	71/94	71/95	72/95	73/95	74/95	74/96	75/96
	60	Q [m ³ ·h ⁻¹]	622	688	711	757	810	864	926	982	1043	1113
T ₃ [°C]		83	81	81	81	80	80	80	79	79	79	79
P _e [kW]		13,8	14,7	15,5	16,3	17,4	18,4	19,7	21,2	22,5	23,6	25
P _m [kW]		18,5	18,5	18,5	22	22	22	30	30	30	30	30
n [min ⁻¹]		2634	2791	2940	3103	3287	3473	3688	3882	4097	4338	4609
n _m [min ⁻¹]		2940	2940	2940	2945	2945	2945	2950	2950	2950	2950	2950
Elmotor		160-2	160-2	160-2	180-2	180-2	180-2	200-2	200-2	200-2	200-2	200-2
i		224/250	224/236	224/224	236/224	250/224	250/212	250/200	250/190	250/180	250/170	250/160
X		2/XPA	2/XPA	2/XPA	2/XPA	2/XPA	2/XPA	2/XPA	2/XPA	2/XPA	2/XPA	2/XPA
L _{MA} [dB]		68/93	69/93	69/93	70/94	71/95	72/95	72/96	74/96	75/97	75/97	76/97
70		Q [m ³ ·h ⁻¹]	616	661	705	752	805	858	919	974	1036	1105
	T ₃ [°C]	94	92	92	91	91	90	90	89	89	89	89
	P _e [kW]	16	17	18	19	20,2	21,5	22,8	24,1	26	27,3	29,2
	P _m [kW]	22	22	22	22	30	30	30	30	30	37	37
	n [min ⁻¹]	2639	2795	2945	3108	3292	3479	3688	3882	4097	4338	4609
	n _m [min ⁻¹]	2945	2945	2945	2945	2950	2950	2950	2950	2950	2950	2950
	Elmotor	180-2	180-2	180-2	180-2	200-2	200-2	200-2	200-2	200-2	200-2	200-2
	i	224/250	224/236	224/224	236/224	250/224	250/212	250/200	250/190	250/180	250/170	250/160
	X	2/XPA	2/XPA	2/XPA	2/XPA	2/XPA	2/XPA	2/XPA	2/XPA	2/XPA	2/XPA	2/XPA
	L _{MA} [dB]	69/93	69/93	70/95	70/95	71/95	72/96	73/96	74/96	75/97	75/97	75/97
	80	Q [m ³ ·h ⁻¹]	611	656	700	745	798	852	912	968	1030	1099
T ₃ [°C]		105	103	103	102	101	100	100	99	99	99	98
P _e [kW]		18,2	19,4	20,5	21,6	23	24,4	25,9	27,9	29,5	31	33,2
P _m [kW]		22	30	30	30	30	30	37	37	37	37	45
n [min ⁻¹]		2643	2800	2950	3108	3292	3479	3688	3882	4097	4338	4617
n _m [min ⁻¹]		2945	2950	2950	2950	2950	2950	2950	2950	2950	2950	2955
Elmotor		200-2	200-2	200-2	200-2	200-2	200-2	200-2	200-2	200-2	200-2	200-2
i		224/250	224/236	224/224	236/224	250/224	250/212	250/200	250/190	250/180	250/170	250/160
X		2/XPA	2/XPA	2/XPA	2/XPA	2/XPA	2/XPA	2/XPA	2/XPA	2/XPA	2/XPA	3/XPA
L _{MA} [dB]		70/94	69/93	70/94	71/95	72/96	73/96	73/97	74/98	75/98	75/98	75/98
90		Q [m ³ ·h ⁻¹]	605	651	694	740	793	847	907	963	1025	1095
	T ₃ [°C]	116	114	114	113	112	110	110	109	109	108	108
	P _e [kW]	20,4	21,8	23	24,2	26	27,4	30	31,2	32,6	34,7	37,1
	P _m [kW]	30	30	30	30	30	37	37	37	45	45	45
	n [min ⁻¹]	2643	2800	2950	3108	3292	3479	3688	3882	4104	4346	4617
	n _m [min ⁻¹]	2950	2950	2950	2950	2950	2950	2950	2950	2955	2955	2955
	Elmotor	200-2	200-2	200-2	200-2	200-2	200-2	200-2	200-2	200-2	200-2	200-2
	i	224/250	224/236	224/224	236/224	250/224	250/212	250/200	250/190	250/180	250/170	250/160
	X	2/XPA	2/XPA	2/XPA	2/XPA	2/XPA	2/XPA	2/XPA	2/XPA	3/XPA	3/XPA	3/XPA
	L _{MA} [dB]	70/93	70/94	71/94	72/95	73/96	73/96	74/96	75/97	76/99	76/99	76/99
	100	Q [m ³ ·h ⁻¹]	601	646	689	735	788	842	903	959	1021	1090
T ₃ [°C]		127	125	124	123	121	121	120	120	119	118	
P _e [kW]		22,6	24,2	25,5	26,8	28,6	30,3	32,3	34,1	36,1	38,5	
P _m [kW]		30	30	30	37	37	37	45	45	45	45	
n [min ⁻¹]		2643	2800	2950	3108	3292	3479	3694	3888	4104	4346	
n _m [min ⁻¹]		2950	2950	2950	2950	2950	2950	2955	2955	2955	2955	
Elmotor		200-2	200-2	200-2	200-2	200-2	200-2	200-2	200-2	200-2	200-2	
i		224/250	224/236	224/224	236/224	250/224	250/212	250/200	250/190	250/180	250/170	
X		2/XPA	2/XPA	2/XPA	2/XPA	2/XPA	2/XPA	3/XPA	3/XPA	3/XPA	3/XPA	
L _{MA} [dB]		72/96	72/96	72/96	73/96	74/97	74/97	75/98	76/99	77/100	77/100	

CZ Dmychadlová soustrojí pro přetlak

UK Blower packages for pressure

D Gebläseaggregate für Überdruck

RU Нагнетательные агрегаты

DT 65/102



Δp [kPa]	DT 65/102 DN 100											
	707	753	809	897	961	1022	1084	1157	1231	1304	1390	
30	Q [m ³ ·h ⁻¹]	707	753	809	897	961	1022	1084	1157	1231	1304	1390
	T ₃ [°C]	51	50	50	50	49	49	49	49	49	49	49
	P _e [kW]	7,7	8,2	8,7	9,6	10,2	10,7	11,3	12,1	12,8	13,6	14,4
	P _m [kW]	11	11	11	15	15	15	15	15	15	18,5	18,5
	n [min ⁻¹]	1629	1718	1817	1993	2117	2234	2363	2499	2634	2775	2940
	n _m [min ⁻¹]	1460	1460	1460	2940	2940	2940	2940	2940	2940	2940	2940
	Elmotor	160-4	160-4	160-4	160-2	160-2	160-2	160-2	160-2	160-2	160-2	160-2
	i	250/224	200/170	224/180	160/236	180/250	190/250	180/224	170/200	224/250	236/250	250/250
	X	2/XPA	2/XPA	2/XPA	2/XPA	2/XPA	2/XPA	2/XPA	2/XPA	2/XPA	2/XPA	2/XPA
	L _{MA} [dB]	72/90	73/91	74/92	75/92	75/93	76/93	76/94	77/94	77/95	77/96	78/97
40	Q [m ³ ·h ⁻¹]	689	768	788	880	944	1005	1073	1143	1216	1293	1376
	T ₃ [°C]	62	61	61	60	60	59	59	59	59	58	58
	P _e [kW]	10,2	10,9	11,5	12,7	13,4	14,2	14,9	15,9	16,9	17,9	19
	P _m [kW]	15	15	15	15	18,5	18,5	18,5	18,5	22	22	22
	n [min ⁻¹]	1629	1718	1817	1993	2117	2234	2363	2499	2639	2785	2945
	n _m [min ⁻¹]	1460	1460	1460	2940	2940	2940	2940	2940	2945	2945	2945
	Elmotor	160-4	160-4	160-4	160-2	160-2	160-2	160-2	160-2	180-2	180-2	180-2
	i	250/224	200/170	224/180	160/236	180/250	190/250	180/224	170/200	224/250	236/250	250/250
	X	2/XPA	2/XPA	2/XPA	2/XPA	2/XPA	2/XPA	2/XPA	2/XPA	2/XPA	2/XPA	2/XPA
	L _{MA} [dB]	74/91	75/92	75/92	76/93	76/94	77/94	77/95	77/95	77/96	77/96	78/98
50	Q [m ³ ·h ⁻¹]	675	727	776	867	932	992	1061	1131	1205	1279	1365
	T ₃ [°C]	73	72	71	71	70	70	69	69	68	68	68
	P _e [kW]	12,7	13,5	14,3	15,8	16,6	17,6	18,6	19,8	20,9	22,2	23,5
	P _m [kW]	15	18,5	18,5	18,5	22	22	22	30	30	30	30
	n [min ⁻¹]	1629	1728	1823	1997	2120	2235	2367	2502	2643	2785	2950
	n _m [min ⁻¹]	1460	1465	1465	2945	2945	2945	2945	2950	2950	2950	2950
	Elmotor	160-4	180-4	180-4	160-2	180-2	180-2	180-2	200-2	200-2	200-2	200-2
	i	250/224	250/212	224/180	160/236	180/250	170/224	180/224	212/250	224/250	236/250	250/250
	X	2/XPA	2/XPA	2/XPA	2/XPA	2/XPA	2/XPA	2/XPA	2/XPA	2/XPA	2/XPA	2/XPA
	L _{MA} [dB]	75/92	75/92	76/93	76/94	77/94	77/95	77/95	77/96	77/96	78/98	78/99
60	Q [m ³ ·h ⁻¹]	666	715	764	857	922	982	1045	1119	1193	1267	1353
	T ₃ [°C]	84	83	83	82	81	80	79	79	78	78	78
	P _e [kW]	15,3	16,2	17,1	18,8	19,9	21,1	22,2	23,7	25	26,4	28
	P _m [kW]	18,5	22	22	22	30	30	30	30	30	37	37
	n [min ⁻¹]	1635	1728	1823	2000	2124	2239	2360	2502	2643	2785	2950
	n _m [min ⁻¹]	1465	1465	1465	2950	2950	2950	2950	2950	2950	2950	2950
	Elmotor	180-4	180-4	180-4	180-2	200-2	200-2	200-2	200-2	200-2	200-2	200-2
	i	250/224	250/212	224/180	160/236	180/250	170/224	200/250	212/250	224/250	236/250	250/250
	X	2/XPA	2/XPA	2/XPA	2/XPA	2/XPA	2/XPA	2/XPA	2/XPA	2/XPA	2/XPA	2/XPA
	L _{MA} [dB]	75/93	76/93	76/94	77/95	77/95	77/96	78/96	78/97	78/97	78/99	79/100
70	Q [m ³ ·h ⁻¹]	656	704	758	850	912	972	1035	1109	1183	1257	1344
	T ₃ [°C]	96	95	94	92	91	91	90	89	89	88	88
	P _e [kW]	17,7	18,8	19,9	21,9	23,2	24,5	25,8	27,5	29,1	30,7	32,7
	P _m [kW]	22	22	30	30	30	30	30	37	37	37	45
	n [min ⁻¹]	1635	1728	1831	2006	2124	2242	2360	2502	2643	2785	2955
	n _m [min ⁻¹]	1465	1465	1465	2950	2950	2950	2950	2950	2950	2950	2955
	Elmotor	180-4	180-4	200-4	200-2	200-2	200-2	200-2	200-2	200-2	200-2	200-2
	i	250/224	250/212	250/200	170/250	180/250	190/250	200/250	212/250	224/250	236/250	250/250
	X	2/XPA	2/XPA	2/XPA	2/XPA	2/XPA	2/XPA	2/XPA	2/XPA	2/XPA	2/XPA	3/XPA
	L _{MA} [dB]	76/93	76/94	77/95	77/95	77/96	78/96	78/97	78/97	78/99	79/100	80/101
80	Q [m ³ ·h ⁻¹]	647	696	750	841	903	963	1027	1101	1175	1250	1336
	T ₃ [°C]	108	107	105	103	102	101	100	99	99	99	98
	P _e [kW]	20,2	21,5	22,7	25	26,4	27,9	29,5	31,3	33,2	35,1	37,3
	P _m [kW]	30	30	30	30	37	37	37	37	45	45	45
	n [min ⁻¹]	1635	1728	1831	2006	2124	2242	2360	2502	2648	2790	2955
	n _m [min ⁻¹]	1465	1465	1465	2950	2950	2950	2950	2950	2955	2955	2955
	Elmotor	200-4	200-4	200-4	200-2	200-2	200-2	200-2	200-2	200-2	200-2	200-2
	i	250/224	250/212	250/200	170/250	180/250	190/250	200/250	212/250	224/250	236/250	250/250
	X	2/XPA	2/XPA	2/XPA	2/XPA	2/XPA	3/XPA	3/XPA	3/XPA	3/XPA	3/XPA	3/XPA
	L _{MA} [dB]	76/94	77/95	77/95	77/96	78/96	78/97	78/97	78/99	79/100	80/101	80/102
90	Q [m ³ ·h ⁻¹]	640	688	742	834	896	956	1020	1094	1168	1242	
	T ₃ [°C]	120	118	117	114	113	112	111	111	110	109	
	P _e [kW]	22,8	24,1	25,5	28	29,7	31,4	33,2	35,3	37,3	39,4	
	P _m [kW]	30	30	30	37	37	37	45	45	45	45	
	n [min ⁻¹]	1635	1728	1831	2006	2124	2242	2364	2506	2648	2790	
	n _m [min ⁻¹]	1465	1465	1465	2950	2950	2950	2955	2955	2955	2955	
	Elmotor	200-4	200-4	200-4	200-2	200-2	200-2	200-2	200-2	200-2	200-2	
	i	250/224	250/212	250/200	170/250	180/250	190/250	200/250	212/250	224/250	236/250	
	X	3/XPA	3/XPA	3/XPA	3/XPA	3/XPA	3/XPA	3/XPA	3/XPA	3/XPA	3/XPA	
	L _{MA} [dB]	77/95	77/95	77/96	78/96	78/97	78/97	78/97	78/99	79/100	80/101	
100	Q [m ³ ·h ⁻¹]	634	682	736	828	890	952	1014	1088			
	T ₃ [°C]	132	130	128	126	125	123	122	121			
	P _e [kW]	25,3	26,8	28,3	31,1	33,1	35	36,8	39,1			
	P _m [kW]	30	37	37	37	45	45	45	45			
	n [min ⁻¹]	1635	1728	1831	2006	2128	2246	2364	2506			
	n _m [min ⁻¹]	1465	1465	1465	2950	2955	2955	2955	2955			
	Elmotor	200-4	200-4	200-4	200-2	200-2	200-2	200-2	200-2			
	i	250/224	250/212	250/200	170/250	180/250	190/250	200/250	212/250			
	X	3/XPA	3/XPA	3/XPA	3/XPA	3/XPA	3/XPA	3/XPA	3/XPA			
	L _{MA} [dB]	77/95	77/96	78/96	78/97	78/97	78/97	78/99	79/100			

Δp [kPa]		DT 66/202 DN 150											DT 66/202*	
		997	1070	1143	1220	1292	1380	1467	1569	1662	1759	1883	1991	2128
30	Q [m ³ ·h ⁻¹]	997	1070	1143	1220	1292	1380	1467	1569	1662	1759	1883	1991	2128
	T ₃ [°C]	50	50	50	49	49	49	49	49	49	49	49	49	49
	P _e [kW]	10,8	11,5	12,2	12,9	13,7	14,5	15,4	16,5	17,5	18,5	19,8	21,2	22,7
	P _m [kW]	15	15	15	15	18,5	18,5	22	22	22	22	30	30	30
	n [min ⁻¹]	1880	1985	2107	2231	2358	2489	2630	2795	2945	3103	3304	3479	3688
	n _m [min ⁻¹]	2925	2925	2925	2925	2935	2935	2935	2945	2945	2945	2950	2950	2950
	Elmotor	160-2	160-2	160-2	160-2	160-2	160-2	160-2	180-2	180-2	180-2	200-2	200-2	200-2
	i	180/280	190/280	170/236	180/236	180/224	212/250	224/250	224/236	200/200	236/224	280/250	250/212	250/200
	X	1/XPB	1/XPB	1/XPB	1/XPB	1/XPB	1/XPB	1/XPB	1/XPB	1/XPB	2/XPB	2/XPB	2/XPB	2/XPB
	L _{mA} [dB]	74/91	75/92	75/92	76/93	76/94	77/94	77/95	77/95	77/96	77/96	78/98	78/99	79/100
40	Q [m ³ ·h ⁻¹]	981	1055	1132	1203	1285	1369	1460	1553	1646	1744	1865	1973	2103
	T ₃ [°C]	61	60	60	60	59	59	59	59	59	58	58	58	58
	P _e [kW]	14,2	15,1	16,1	17	18	19,1	20,3	21,6	22,9	24,1	25,8	27,5	29,5
	P _m [kW]	18,5	18,5	22	22	22	30	30	30	30	30	30	37	37
	n [min ⁻¹]	1887	1992	2121	2235	2367	2502	2650	2800	2950	3108	3304	3479	3688
	n _m [min ⁻¹]	2935	2935	2945	2945	2945	2950	2950	2950	2950	2950	2950	2950	2950
	Elmotor	160-2	160-2	180-2	180-2	180-2	200-2	200-2	200-2	200-2	200-2	200-2	200-2	200-2
	i	180/280	190/280	170/236	170/224	180/224	212/250	212/236	224/236	200/200	236/224	280/250	250/212	250/200
	X	1/XPB	1/XPB	2/XPB	2/XPB	2/XPB	2/XPB	2/XPB	2/XPB	2/XPB	2/XPB	2/XPB	2/XPB	2/XPB
	L _{mA} [dB]	74/92	75/93	76/93	76/94	77/95	77/95	77/96	78/96	78/97	78/97	78/99	79/100	80/101
50	Q [m ³ ·h ⁻¹]	975	1040	1118	1191	1265	1353	1445	1538	1631	1729	1850	1963	2091
	T ₃ [°C]	71	70	70	70	69	69	69	68	68	68	68	68	68
	P _e [kW]	17,8	18,8	20	21,2	22,3	23,7	25,2	26,7	28,3	29,9	31,8	34	36,5
	P _m [kW]	22	22	30	30	30	30	30	37	37	37	37	45	45
	n [min ⁻¹]	1893	1998	2124	2242	2360	2502	2650	2800	2950	3108	3304	3487	3694
	n _m [min ⁻¹]	2945	2945	2950	2950	2950	2950	2950	2950	2950	2950	2950	2955	2955
	Elmotor	180-2	180-2	200-2	200-2	200-2	200-2	200-2	200-2	200-2	200-2	200-2	225-2	225-2
	i	180/280	190/280	180/250	190/250	200/250	212/250	212/236	224/236	200/200	236/224	280/250	236/200	250/200
	X	2/XPB	2/XPB	2/XPB	2/XPB	2/XPB	2/XPB	2/XPB	2/XPB	2/XPB	2/XPB	2/XPB	2/XPB	2/XPB
	L _{mA} [dB]	74/92	75/93	76/93	76/94	77/95	77/95	77/96	78/96	78/97	78/97	78/99	79/100	80/101
60	Q [m ³ ·h ⁻¹]	963	1029	1105	1178	1251	1340	1432	1525	1620	1724	1829	1958	2072
	T ₃ [°C]	82	81	81	80	79	79	79	78	78	77	77	77	77
	P _e [kW]	21,2	22,5	23,9	25,2	26,6	28,2	30	31,8	33,7	35,7	37,8	41,5	43
	P _m [kW]	30	30	30	30	37	37	37	37	45	45	45	55	55
	n [min ⁻¹]	1896	2002	2124	2242	2360	2502	2650	2800	2955	3122	3290	3499	3683
	n _m [min ⁻¹]	2950	2950	2950	2950	2950	2950	2950	2950	2955	2955	2955	2965	2965
	Elmotor	200-2	200-2	200-2	200-2	200-2	200-2	200-2	200-2	225-2	225-2	225-2	250-2	250-2
	i	180/280	190/280	180/250	190/250	200/250	212/250	212/236	224/236	250/250	224/212	236/212	236/200	236/190
	X	2/XPB	2/XPB	2/XPB	2/XPB	2/XPB	2/XPB	2/XPB	2/XPB	2/XPB	2/XPB	2/XPB	2/XPB	3/XPB
	L _{mA} [dB]	75/93	75/94	76/94	76/95	77/96	77/96	77/97	78/97	78/98	79/98	79/100	80/101	81/102
70	Q [m ³ ·h ⁻¹]	952	1018	1094	1167	1240	1330	1423	1512	1610	1725	1837	1947	
	T ₃ [°C]	93	92	91	90	90	90	89	88	88	87	87	87	
	P _e [kW]	24,7	26,1	27,7	29,3	30,9	32,8	34,9	36,9	39	41,7	44,2	47,1	
	P _m [kW]	30	37	37	37	37	45	45	45	45	55	55	55	
	n [min ⁻¹]	1896	2002	2124	2242	2360	2504	2654	2797	2955	3141	3321	3499	
	n _m [min ⁻¹]	2950	2950	2950	2950	2950	2955	2955	2955	2955	2965	2965	2965	
	Elmotor	200-2	200-2	200-2	200-2	200-2	225-2	225-2	225-2	225-2	250-2	250-2	250-2	
	i	180/280	190/280	180/250	190/250	200/250	200/236	212/236	212/224	250/250	250/236	224/200	236/200	
	X	2/XPB	2/XPB	2/XPB	2/XPB	2/XPB	2/XPB	2/XPB	2/XPB	2/XPB	2/XPB	2/XPB	3/XPB	
	L _{mA} [dB]	75/94	76/94	76/95	77/96	77/96	77/97	78/97	78/98	79/98	79/100	80/101	81/102	
80	Q [m ³ ·h ⁻¹]	942	1008	1084	1160	1233	1321	1414	1504	1606	1715			
	T ₃ [°C]	104	103	102	101	100	99	99	98	98	97			
	P _e [kW]	28,1	29,7	31,6	33,4	35,3	37,4	39,7	42	44,6	47,4			
	P _m [kW]	37	37	37	45	45	45	45	55	55	55			
	n [min ⁻¹]	1896	2002	2124	2246	2364	2504	2654	2799	2965	3140			
	n _m [min ⁻¹]	2950	2950	2950	2955	2955	2955	2955	2965	2965	2965			
	Elmotor	200-2	200-2	200-2	225-2	225-2	225-2	225-2	250-2	250-2	250-2			
	i	180/280	190/280	180/250	190/250	200/250	200/236	212/236	236/250	250/250	250/236			
	X	2/XPB	2/XPB	2/XPB	2/XPB	2/XPB	2/XPB	2/XPB	2/XPB	2/XPB	2/XPB			
	L _{mA} [dB]	76/95	77/96	77/96	77/97	78/97	78/98	79/98	79/100	80/101	81/102			
90	Q [m ³ ·h ⁻¹]	934	1004	1080	1152	1225	1318	1416						
	T ₃ [°C]	115	114	113	111	110	109	109						
	P _e [kW]	31,6	33,4	35,5	37,6	39,6	42,1	44,5						
	P _m [kW]	37	45	45	45	45	55	55						
	n [min ⁻¹]	1896	2007	2129	2246	2364	2513	2647						
	n _m [min ⁻¹]	2950	2955	2955	2955	2955	2965	2965						
	Elmotor	200-2	225-2	225-2	225-2	225-2	250-2	250-2						
	i	180/280	170/250	170/236	190/250	200/250	200/236	200/224						
	X	2/XPB	3/XPB	3/XPB	2/XPB	2/XPB	2/XPB	2/XPB						
	L _{mA} [dB]	77/96	77/97	78/97	78/98	79/98	79/100	80/101						
100	Q [m ³ ·h ⁻¹]	928	997	1061	1144	1223								
	T ₃ [°C]	127	125	124	122	121								
	P _e [kW]	35	37,1	39,1	41,7	44,1								
	P _m [kW]	45	45	45	55	55								
	n [min ⁻¹]	1896	2007	2119	2261	2387								
	n _m [min ⁻¹]	2955	2955	2955	2965	2965								
	Elmotor	225-2	225-2	225-2	250-2	250-2								
	i	180/280	170/250	170/236	180/236	190/236								
	X	3/XPB	3/XPB	3/XPB	3/XPB	3/XPB								
	L _{mA} [dB]	78/97	78/98	79/98	79/100	80/101								

-  Dmychadlová soustrojí pro přetlak
 Blower packages for pressure
 Gebläseaggregate für Überdruck
 Нагнетательные агрегаты

DT 70/202

DT 70/302



Δp [kPa]		DT 70/202 DN 150							DT 70/302 DN 200				
		1427	1626	1923	2049	2183	2314	2451	2612	2772	2940	3126	
30	Q [m ³ ·h ⁻¹]	50	50	50	50	50	50	49	49	49	49	49	
	T ₃ [°C]	15,8	18	20,9	22,2	23,7	25,1	26,7	28,6	30,5	32,5	34,8	
	P _e [kW]	18,5	22	30	30	30	30	37	37	37	45	45	
	P _m [kW]	1460	1635	1896	2006	2124	2239	2360	2501	2643	2790	2955	
	n [min ⁻¹]	1460	1465	2950	2950	2950	2950	2950	2950	2950	2955	2955	
	n _m [min ⁻¹]	180-4	180-4	200-2	200-2	200-2	200-2	200-2	200-2	200-2	225-2	225-2	
	Elmotor	i	236/236	250/224	180/280	170/250	180/250	170/224	200/250	212/250	224/250	236/250	250/250
	X	2/XPB	2/XPB	2/XPB	2/XPB	2/XPB	2/XPB	2/XPB	2/XPB	2/XPB	2/XPB	2/XPB	2/XPB
	L _{MA} [dB]	73/95	74/96	75/97	76/98	76/98	77/99	77/99	77/99	77/98	78/99	79/100	80/100
	40	Q [m ³ ·h ⁻¹]	60	59	59	59	59	59	59	60	58	60	58
T ₃ [°C]		20,8	23	27,3	28,9	30,8	32,9	34,7	37,6	39,4	42	44,9	
P _e [kW]		30	30	37	37	37	45	45	45	45	55	55	
P _m [kW]		1465	1635	1896	2006	2124	2254	2364	2541	2648	2799	2965	
n [min ⁻¹]		1465	1465	2950	2950	2950	2955	2955	2955	2955	2965	2965	
n _m [min ⁻¹]		200-4	200-4	200-2	200-2	200-2	225-2	225-2	225-2	225-2	250-2	250-2	
Elmotor		i	212/212	250/224	180/280	170/250	180/250	180/236	200/250	215/250	224/250	236/250	250/250
X		2/XPB	2/XPB	2/XPB	2/XPB	2/XPB	2/XPB	2/XPB	2/XPB	2/XPB	2/XPB	2/XPB	2/XPB
L _{MA} [dB]		71/95	75/97	76/98	76/98	77/99	77/99	78/100	78/99	78/100	79/101	81/102	
50		Q [m ³ ·h ⁻¹]	71	71	70	70	69	69	69	69	67	69	67
	T ₃ [°C]	25,7	29	33,7	35,9	37,7	40,4	43	46,3	48,3	51,6	55	
	P _e [kW]	30	37	45	45	45	55	55	55	55	75	75	
	P _m [kW]	1465	1642	1900	2016	2128	2250	2387	2550	2657	2809	2975	
	n [min ⁻¹]	1465	1475	2955	2955	2955	2965	2965	2965	2965	2975	2975	
	n _m [min ⁻¹]	200-4	225-4	225-2	225-2	225-2	250-2	250-2	250-2	250-2	280-2	280-2	
	Elmotor	i	212/212	236/212	180/280	170/250	180/250	170/224	190/236	215/250	224/250	236/250	250/250
	X	3/XPB	3/XPB	3/XPB	3/XPB	3/XPB	3/XPB	3/XPB	2/XPB	2/XPB	2/XPB	2/XPB	
	L _{MA} [dB]	74/96	75/97	76/98	77/99	76/99	78/100	79/101	79/100	79/101	81/102	82/103	
	60	Q [m ³ ·h ⁻¹]	81	81	80	80	79	79	79	79	77	78	76
T ₃ [°C]		30,8	34,4	40	42,6	45,3	48	50,8	53,8	57,3	61,1	65	
P _e [kW]		37	45	55	55	55	65	65	75	75	75	75	
P _m [kW]		1475	1642	1898	2016	2135	2253	2376	2503	2656	2809	2975	
n [min ⁻¹]		1475	1475	2965	2965	2965	2965	2970	2970	2975	2975	2975	
n _m [min ⁻¹]		225-4	225-4	250-2	250-2	250-2	250-2	280-2	280-2	280-2	280-2	280-2	
Elmotor		i	224/224	236/212	160/250	170/250	180/250	190/250	224/280	236/280	250/280	236/250	280/280
X		3/XPB	3/XPB	3/XPB	3/XPB	3/XPB	3/XPB	3/XPB	3/XPB	3/XPB	3/XPB	3/XPB	
L _{MA} [dB]		74/96	76/98	77/99	77/99	78/100	78/100	78/100	79/101	80/101	81/102	82/104	
70		Q [m ³ ·h ⁻¹]	92	90	90	90	89	89	88	88	87	88	
	T ₃ [°C]	35,8	41	46,6	49,4	52,1	55,5	58,8	62,2	66,4	70,6		
	P _e [kW]	45	55	65	75	75	75	85	85	90	90		
	P _m [kW]	1475	1658	1906	2015	2121	2249	2376	2503	2656	2809		
	n [min ⁻¹]	1475	1480	2965	2970	2970	2970	2970	2970	2975	2975		
	n _m [min ⁻¹]	225-4	250-4	250-2	280-2	280-2	280-2	280-2	280-2	280-2	280-2		
	Elmotor	i	236/236	280/250	180/280	190/280	200/280	212/280	224/280	236/280	250/280	236/250	
	X	3/XPB	3/XPB	3XPB	3/XPB	3/XPB	3/XPB	3/XPB	3/XPB	3/XPB	3/XPB	3/XPB	
	L _{MA} [dB]	75/97	76/98	77/99	76/98	77/99	77/99	78/100	79/101	80/102	81/102		
	80	Q [m ³ ·h ⁻¹]	104	103	101	100	99	99	98	98	97		
T ₃ [°C]		40,9	46,1	52,4	55,7	59,0	62,4	66,3	70,9	75			
P _e [kW]		55	65	75	75	75	85	85	90	90			
P _m [kW]		1480	1665	1885	1999	2112	2225	2357	2508	2644			
n [min ⁻¹]		1480	1480	2970	2970	2970	2970	2970	2975	2975			
n _m [min ⁻¹]		250-4	250-4	280-2	280-2	280-2	280-2	280-2	280-2	280-2			
Elmotor		i	300/300	315/280	200/315	212/315	224/315	236/315	250/315	236/280	280/315		
X		3/XPB	4/XPB	3/XPB	3/XPB	3/XPB	3/XPB	3/XPB	3/XPB	3/XPB	3/XPB		
L _{MA} [dB]		75/97	77/99	76/98	77/99	77/99	78/100	79/101	80/102	80/102			
90		Q [m ³ ·h ⁻¹]	115	113	111	110	109	109					
	T ₃ [°C]	45,9	51,8	58,8	62,5	66,2	70						
	P _e [kW]	55	75	75	75	75	90						
	P _m [kW]	1480	1667	1885	1999	2112	2229						
	n [min ⁻¹]	1480	1480	2970	2970	2970	2975						
	n _m [min ⁻¹]	250-4	280-4	280-2	280-2	280-2	280-2						
	Elmotor	i	300/300	315/280	200/315	212/315	224/315	236/315					
	X	3/XPB	3/XPB	3/XPB	3/XPB	3/XPB	3/XPB	3/XPB					
	L _{MA} [dB]	75/97	76/98	77/99	78/100	78/100	79/101						
	100	Q [m ³ ·h ⁻¹]	127	124	121	120							
T ₃ [°C]		50,8	57,5	65,3	69,4								
P _e [kW]		75	75	75	90								
P _m [kW]		1480	1684	1889	2002								
n [min ⁻¹]		1480	2970	2970	2975								
n _m [min ⁻¹]		280-4	280-2	280-2	280-2								
Elmotor		i	335/335	190/335	212/335	224/335							
X		3/XPB	4/XPB	4/XPB	4/XPB								
L _{MA} [dB]		76/98	77/99	78/100	78/100								

- CZ** Dmychadlová soustrojí pro přetlak
UK Blower packages for pressure
D Gebläseaggregate für Überdruck
RU Нагнетательные агрегаты

DT 90/302

DT 90/552



Δp [kPa]		DT 90/302 DN 200									DT 90/552 DN 250			
		2500	2648	2800	3004	3247	3442	3694	3934	4184	4445	4790	5108	5750
30	Q [m ³ ·h ⁻¹]	2500	2648	2800	3004	3247	3442	3694	3934	4184	4445	4790	5108	5750
	T ₃ [°C]	50	50	50	50	50	50	50	50	50	50	50	51	51
	P _e [kW]	28	29,5	30,1	35	36	38	41	43	47	50	54	57,7	66,3
	P _m [kW]	37	37	37	45	45	45	55	55	55	75	75	75	75
	n [min ⁻¹]	1404	1475	1548	1651	1764	1860	1980	2096	2217	2343	2509	2664	2975
	n _m [min ⁻¹]	1475	1475	1475	1475	1475	2955	2970	2970	2970	2975	2975	2975	2975
	Elmotor	225-4	225-4	225-4	225-4	225-4	225-2	250-2	250-2	250-2	280-2	280-2	280-2	280-2
	i	300/315	300/300	315/300	375/335	335/280	236/375	300/450	300/425	280/375	315/400	300/355	300/335	300/300
	X	3/XPC	3/XPC	3/XPC	3/XPC	3/XPC	3/XPC	3/XPC	3/XPC	3/XPC	3/XPC	3/XPC	3/XPC	3/XPC
	L _{MA} [dB]	73/94	73/94	74/95	75/95	76/96	76/97	77/97	78/99	79/103	81/101	81/106	82/106	83/107
40	Q [m ³ ·h ⁻¹]	2453	2596	2763	2970	3211	3379	3605	3860	4146	4398	4740	5062	5716
	T ₃ [°C]	61	61	61	60	60	60	60	60	60	60	60	60	60
	P _e [kW]	37	38	41	45	47	49	53	56	60	64	69	73,9	84,7
	P _m [kW]	45	45	55	55	55	75	75	75	75	75	90	90	110
	n [min ⁻¹]	1404	1475	1554	1657	1770	1851	1960	2083	2221	2343	2514	2664	2980
	n _m [min ⁻¹]	1475	1475	1480	1480	1480	2975	2975	2975	2975	2975	2975	2975	2980
	Elmotor	225-4	225-4	250-4	250-4	250-4	280-2	280-2	280-2	280-2	280-2	280-2	280-2	315-2
	i	300/315	300/300	315/300	375/335	335/280	280/450	280/425	315/450	280/375	315/400	300/355	300/335	300/300
	X	3/XPC	3/XPC	3/XPC	3/XPC	3/XPC	3/XPC	3/XPC	3/XPC	3/XPC	3/XPC	3/XPC	3/XPC	3/XPC
	L _{MA} [dB]	74/96	74/96	75/97	76/97	77/97	77/98	78/99	79/100	82/105	83/106	84/106	85/107	85/108
50	Q [m ³ ·h ⁻¹]	2422	2567	2737	2952	3147	3338	3565	3820	4106	4359	4699	5032	5678
	T ₃ [°C]	72	71	71	70	70	70	70	70	70	70	69	69	69
	P _e [kW]	45	48	52	54	59	61	64	69	74	78	84	90,5	103,0
	P _m [kW]	55	55	75	75	75	75	90	90	90	90	110	110	132
	n [min ⁻¹]	1409	1480	1564	1665	1762	1851	1960	2083	2221	2343	2507	2668	2980
	n _m [min ⁻¹]	1480	1480	1480	1480	1480	2975	2975	2975	2975	2975	2980	2980	2980
	Elmotor	250-4	250-4	280-4	280-4	280-4	280-2	280-2	280-2	280-2	280-2	315-2	315-2	315-2
	i	300/315	300/300	280/265	315/280	375/315	280/450	280/425	315/450	280/375	315/400	265/315	300/335	300/300
	X	3/XPC	3/XPC	3/XPC	3/XPC	3/XPC	3/XPC	3/XPC	3/XPC	3/XPC	3/XPC	3/XPC	3/XPC	3/XPC
	L _{MA} [dB]	75/98	75/98	76/98	77/99	78/99	78/102	79/101	80/102	83/106	83/107	84/107	85/107	86/109
60	Q [m ³ ·h ⁻¹]	2372	2531	2703	2917	3126	3303	3530	3783	4078	4340	4665	4999	
	T ₃ [°C]	82	82	82	81	80	80	80	80	79	79	79	79	
	P _e [kW]	54	57	61	65	70	72	77	81	87	93	100	106,9	
	P _m [kW]	75	75	75	75	90	90	90	90	110	110	110	132	
	n [min ⁻¹]	1405	1480	1564	1665	1768	1851	1960	2082	2224	2350	2507	2668	
	n _m [min ⁻¹]	1485	1480	1480	1480	1485	2975	2975	2975	2980	2980	2980	2980	
	Elmotor	280-4	280-4	280-4	280-4	280-4	280-2	280-2	280-2	315-2	315-2	315-2	315-2	
	i	265/280	300/300	280/265	315/280	375/315	280/450	280/425	315/450	250/335	280/355	265/315	300/335	
	X	3/XPC	3/XPC	3/XPC	3/XPC	3/XPC	3/XPC	3/XPC	3/XPC	3/XPC	3/XPC	3/XPC	3/XPC	
	L _{MA} [dB]	76/99	76/99	77/100	78/100	79/101	79/102	80/103	81/104	82/105	83/106	85/107	86/107	
70	Q [m ³ ·h ⁻¹]	2333	2510	2673	2882	3101	3288	3506	3762	4049	4310	4636		
	T ₃ [°C]	93	93	92	92	91	91	90	90	89	89	88		
	P _e [kW]	63	66	71	76	80	83	95	94	101	107	115		
	P _m [kW]	75	90	90	90	90	110	110	110	132	132	132		
	n [min ⁻¹]	1405	1485	1564	1665	1768	1858	1963	2086	2224	2350	2507		
	n _m [min ⁻¹]	1485	1485	1485	1485	1485	2980	2980	2980	2980	2980	2980		
	Elmotor	280-4	280-4	280-4	280-4	280-4	315-2	315-2	315-2	315-2	315-2	315-2		
	i	265/280	300/300	280/265	450/400	375/315	265/425	280/425	315/450	250/335	280/355	265/315		
	X	3/XPC	3/XPC	3/XPC	3/XPC	3/XPC	3/XPC	4/XPC	4/XPC	4/XPC	4/XPC	4/XPC		
	L _{MA} [dB]	77/101	77/102	78/101	79/102	79/103	80/103	82/106	82/106	83/106	84/107	86/107		
80	Q [m ³ ·h ⁻¹]	2315	2483	2657	2853	3068	3261	3528	3736	4023				
	T ₃ [°C]	105	104	103	102	102	101	101	100	99				
	P _e [kW]	72	75	80	84	90	95	101	107	115				
	P _m [kW]	90	90	90	110	110	110	132	132	132				
	n [min ⁻¹]	1405	1485	1569	1662	1765	1858	1986	2086	2224				
	n _m [min ⁻¹]	1485	1485	1485	1485	1485	2980	2980	2980	2980				
	Elmotor	280-4	280-4	280-4	315-4	315-4	315-2	315-2	315-2	315-2				
	i	265/280	315/315	280/265	375/335	315/265	265/425	300/450	315/450	250/335				
	X	3/XPC	3/XPC	3/XPC	3/XPC	3/XPC	3/XPC	3/XPC	4/XPC	4/XPC				
	L _{MA} [dB]	77/101	77/101	78/102	79/102	80/103	81/104	82/107	82/107	83/107				
90	Q [m ³ ·h ⁻¹]	1955	2110	2292	2460	2634	2850	3007	3238	3505				
	T ₃ [°C]	121	119	116	115	115	112	112	111	111				
	P _e [kW]	70	74	80	84	89	95	101	108	113				
	P _m [kW]	90	90	90	110	110	110	132	132	132				
	n [min ⁻¹]	1243	1318	1405	1485	1568	1673	1778	1882	1986				
	n _m [min ⁻¹]	1485	1485	1485	1485	1485	1485	1485	1485	1485				
	Elmotor	280-4	280-4	280-4	315-4	315-4	315-4	315-4	315-2	315-2				
	i	335/400	355/400	265/280	355/355	475/450	400/355	500/425	265/425	300/450				
	X	3/XPC	3/XPC	3/XPC	3/XPC	3/XPC	3/XPC	3/XPC	3/XPC	4/XPC				
	L _{MA} [dB]	77/99	78/100	78/101	78/102	78/102	79/103	82/105	83/108	83/108				
100	Q [m ³ ·h ⁻¹]	1934	2089	2277	2437	2614	2830	2987	3218					
	T ₃ [°C]	133	131	127,5	126	126	123	123	122					
	P _e [kW]	78	82	88	93	99	106	110	118					
	P _m [kW]	90	110	110	110	110	132	132	132					
	n [min ⁻¹]	1243	1318	1407	1485	1568	1673	1747	1858					
	n _m [min ⁻¹]	1485	1485	1485	1485	1485	1485	1485	1485					
	Elmotor	280-4	315-4	315-4	315-4	315-4	315-4	315-4	315-2					
	i	335/400	355/400	450/475	355/355	475/450	400/355	500/425	265/425					
	X	3/XPC	3/XPC	3/XPC	3/XPC	3/XPC	3/XPC	3/XPC	4/XPC					
	L _{MA} [dB]	78/100	78/101	78/102	79/103	80/103	81/103	84/106	84/109					

DT 100/552

DT 100/802



Δp [kPa]		DT 100/552 DN 250										DT 100/802 DN 300			
		2966	3140	3373	3605	3838	4128	4436	4731	5061	5388	5683	6097	6509	6978
30	Q [m ³ ·h ⁻¹]	51	50	50	50	50	50	50	50	50	50	49,3	49	49	49
	T ₃ [°C]	32,9	34,6	36,9	39,2	41,6	44,5	47,8	50,9	54,4	58	61,5	65	69	74
	P _e [kW]	45	45	45	45	55	55	55	75	75	75	75	90	90	90
	n [min ⁻¹]	1106	1161	1235	1309	1383	1475	1573	1677	1772	1876	1973	2100	2231	2380
	n _m [min ⁻¹]	1475	1475	1475	1475	1475	1475	1475	1480	1480	1480	2975	2975	2975	2975
	Elmotor	225-4	225-4	225-4	225-4	250-4	250-4	250-4	280-4	280-4	280-4	280-2	283-2	283-2	283-2
	i	300/400	315/400	335/400	355/400	375/400	400/400	400/375	425/375	425/355	450/355	315/475	300/425	300/400	300/375
	X	3/XPC	3/XPC	3/XPC	3/XPC	3/XPC	3/XPC	3/XPC	3/XPC	3/XPC	3/XPC	3/XPC	3/XPC	3/XPC	3/XPC
	L _{MA} [dB]	73/94	73/94	74/95	74/95	75/96	76/97	77/97	77/98	78/99	78/100	80/100	80/100	80/100	80/100
	40	Q [m ³ ·h ⁻¹]	61	61	61	60	60	60	59	59	59	58,8	58	58	58
T ₃ [°C]		43,1	45,3	48,3	51,5	54,6	58,5	62,6	66,8	70,9	75,5	80	84,0	89,8	96,4
P _e [kW]		55	55	55	75	75	75	75	90	90	90	110	110	110	
n [min ⁻¹]		1106	1161	1235	1313	1388	1480	1579	1677	1772	1876	1976	2103	2235	2384
n _m [min ⁻¹]		1475	1475	1475	1480	1480	1480	1480	1480	1480	1480	2980	2980	2980	2980
Elmotor		250-4	250-4	250-4	280-4	280-4	280-4	280-4	280-4	280-4	280-4	315,2	315-2	315-2	315-2
i		300/400	315/400	335/400	355/400	375/400	400/400	400/375	425/375	425/355	450/355	315/475	300/425	300/400	300/375
X		3/XPC	3/XPC	3/XPC	3/XPC	3/XPC	3/XPC	3/XPC	3/XPC	3/XPC	3/XPC	3/XPC	3/XPC	3/XPC	3/XPC
L _{MA} [dB]		74/95	74/96	75/97	75/97	76/97	77/97	78/98	78/99	79/100	80/100	81/104	81/104	81/104	81/104
50		Q [m ³ ·h ⁻¹]	72	72	71	71	70	69	69	69	69	68,1	68	67	67
	T ₃ [°C]	53,6	56,4	60,1	63,7	67,6	72,3	76,7	82,8	86,8	93,4	103,8	110,9	119,0	
	P _e [kW]	75	75	75	90	90	90	110	110	110	132	132	132	132	
	n [min ⁻¹]	1110	1166	1240	1313	1388	1480	1579	1683	1778	1882	1976	2103	2235	2384
	n _m [min ⁻¹]	1480	1480	1480	1480	1480	1480	1480	1485	1485	1485	2980	2980	2980	2980
	Elmotor	280-4	280-4	280-4	280-4	280-4	280-4	280-4	315-4	315-4	315-4	315-2	315-2	315-2	315-2
	i	300/400	315/400	335/400	355/400	375/400	400/400	400/375	425/375	425/355	450/355	315/475	300/425	300/400	300/375
	X	3/XPC	3/XPC	3/XPC	3/XPC	3/XPC	3/XPC	3/XPC	3/XPC	3/XPC	3/XPC	3/XPC	3/XPC	3/XPC	4/XPC
	L _{MA} [dB]	75/97	75/98	76/98	76/99	77/99	78/99	79/100	79/101	80/102	80/103	82/105	82/105	82/105	82/105
	60	Q [m ³ ·h ⁻¹]	83	83	82	81	81	80	80	79	79	78	77	77	77
T ₃ [°C]		63,9	67,2	71,6	76	80,5	86,1	91,8	98,6	103,6	111,1	117,5	123,8	132,1	141,7
P _e [kW]		75	90	90	90	110	110	110	132	132	132	160	160	160	
n [min ⁻¹]		1110	1166	1240	1313	1388	1485	1584	1683	1778	1882	1976	2103	2235	2384
n _m [min ⁻¹]		1480	1480	1480	1480	1480	1485	1485	1485	1485	1485	2980	2980	2980	2980
Elmotor		280-4	280-4	280-4	280-4	280-4	315-4	315-4	315-4	315-4	315-4	315-2	315-2	315-2	315-2
i		300/400	315/400	335/400	355/400	375/400	400/400	400/375	425/375	425/355	450/355	315/475	300/425	300/400	300/375
X		3/XPC	3/XPC	3/XPC	3/XPC	3/XPC	3/XPC	3/XPC	3/XPC	3/XPC	3/XPC	3/XPC	4/XPC	4/XPC	4/XPC
L _{MA} [dB]		76/99	76/99	77/100	77/100	78/100	79/101	80/102	80/103	81/104	81/105	84/107	84/107	84/107	84/107
70		Q [m ³ ·h ⁻¹]	95	94	93	92	91	90	90	89	89	88	87,9	87	86
	T ₃ [°C]	74,2	78,1	83,4	88,6	93,7	100,3	106,7	114,4	120,3	128,8	136	143,7	153,4	164,5
	P _e [kW]	90	90	110	110	132	132	132	160	160	160	200	200	200	
	n [min ⁻¹]	1110	1166	1244	1318	1392	1485	1584	1683	1778	1882	1976	2103	2235	2384
	n _m [min ⁻¹]	1480	1480	1485	1485	1485	1485	1485	1485	1485	1485	2980	2980	2980	2980
	Elmotor	280-4	280-4	315-4	315-4	315-4	315-4	315-4	315-4	315-4	315-4	315-2	315-2	315-2	315-2
	i	300/400	315/400	335/400	355/400	375/400	400/400	400/375	425/375	425/355	450/355	315/475	300/425	300/400	300/375
	X	3/XPC	3/XPC	3/XPC	3/XPC	3/XPC	3/XPC	3/XPC	3/XPC	4/XPC	4/XPC	4/XPC	4/XPC	4/XPC	5/XPC
	L _{MA} [dB]	77/100	77/101	78/101	78/102	79/102	80/103	81/104	81/105	82/106	82/107	83/107	83/107	83/107	83/107
	80	Q [m ³ ·h ⁻¹]	106	105	104	103	102	101	100	99	99	98	97,8	97	96
T ₃ [°C]		84,9	89,2	95	100,9	106,7	114,2	121,6	130,2	137,1	146,9	154,5	163,7	174,8	187,4
P _e [kW]		110	110	132	132	132	160	160	160	200	200	200	200	200	250
n [min ⁻¹]		1114	1169	1244	1318	1392	1485	1584	1683	1778	1886	1976	2103	2235	2384
n _m [min ⁻¹]		1485	1485	1485	1485	1485	1485	1485	1485	1485	1488	1488	2980	2980	2980
Elmotor		315-4	315-4	315-4	315-4	315-4	315-4	315-4	315-4	315-4	315-4	315-2	315-2	315-2	317-2
i		300/400	315/400	335/400	355/400	375/400	400/400	400/375	425/375	425/355	450/355	315/475	300/425	300/400	300/375
X		3/XPC	3/XPC	3/XPC	3/XPC	3/XPC	3/XPC	4/XPC	4/XPC	4/XPC	4/XPC	4/XPC	4/XPC	5/XPC	5/XPC
L _{MA} [dB]		77/101	77/101	78/102	79/102	79/103	80/103	81/104	81/105	82/106	82/107	84/108	84/108	84/108	84/108
90		Q [m ³ ·h ⁻¹]	118	117	115	114	113	112	111	110	109	108	107,7	106	106
	T ₃ [°C]	95,2	100,1	106,7	113,2	119,8	128,1	136,5	146,3	154,2	164,7	173,5	183,8	192	
	P _e [kW]	110	132	132	132	160	160	160	200	200	200	200	250	250	
	n [min ⁻¹]	1114	1169	1244	1318	1392	1485	1584	1686	1781	1885	1976	2103	2235	2384
	n _m [min ⁻¹]	1485	1485	1485	1485	1485	1485	1485	1488	1488	1488	2980	2980	2980	2980
	Elmotor	315-4	315-4	315-4	315-4	315-4	315-4	315-4	315-4	315-4	315-4	315-2	317-2	317-2	317-2
	i	300/400	315/400	335/400	355/400	375/400	400/400	400/375	425/375	425/355	475/375	315/475	300/425	300/400	300/375
	X	4/XPC	4/XPC	4/XPC	4/XPC	4/XPC	4/XPC	4/XPC	4/XPC	4/XPC	4/XPC	5/XPC	5/XPC	5/XPC	5/XPC
	L _{MA} [dB]	77/101	77/101	78/102	79/102	80/103	81/104	81/104	82/105	82/106	82/107	85/110	85/110	85/110	85/110
	100	Q [m ³ ·h ⁻¹]	130	128	126	125	124	122	121	120	119	118	117,6	116	116
T ₃ [°C]		105,6	111	118,3	125,5	132,8	142	151,7	162,2	168,7	181,8	192	192	192	
P _e [kW]		132	132	132	160	160	160	200	200	200	200	250	250	250	
n [min ⁻¹]		1114	1169	1244	1318	1392	1485	1587	1674	1750	1887	1976	2103	2235	2384
n _m [min ⁻¹]		1485	1485	1485	1485	1485	1485	1488	1488	1488	1488	2980	2980	2980	2980
Elmotor		315-4	315-4	315-4	315-4	315-4	315-4	315-4	315-4	315-4	315-4	315-2	315-2	315-2	315-2
i		300/400	315/400	335/400	355/400	375/400	400/400	400/375	450/400	500/425	425/335	315/475	300/425	300/400	300/375
X		4/XPC	4/XPC	4/XPC	4/XPC	4/XPC	4/XPC	4/XPC	4/XPC	4/XPC	5/XPC	5/XPC	5/XPC	5/XPC	5/XPC
L _{MA} [dB]		77/101	78/102	78/102	79/103	80/103	81/104	81/104	82/105	82/106	82/106	85/110	85/110	85/110	85/110

Δp [kPa]		DT110/802 DN 300									
		4605	4873	5227	5581	5634	6374	6857	7343	7786	8312
30	Q [m ³ ·h ⁻¹]	4605	4873	5227	5581	5634	6374	6857	7343	7786	8312
	T ₃ [°C]	51	51	51	51	51	51	51	51	49	49
	P _e [kW]	51,2	54	57,8	61,6	65,6	70,5	73,4	82	83,4	89,3
	P _m [kW]	75	75	75	75	75	90	90	110	110	110
	n [min ⁻¹]	1110	1166	1240	1314	1388	1480	1579	1683	1773	1882
	n _m [min ⁻¹]	1480	1480	1480	1480	1480	1480	1480	1485	1485	1485
	Elmotor	280-4	280-4	280-4	280-4	280-4	280-4	280-4	315-4	315-4	315-4
	i	300/400	315/400	335/400	355/400	375/400	400/400	400/375	425/375	400/335	450/355
	X	3/XPC	3/XPC	3/XPC	3/XPC	3/XPC	3/XPC	3/XPC	3/XPC	3/XPC	3/XPC
	L _{mA} [dB]	74/95	74/95	75/96	76/97	76/98	77/98	78/99	79/99	79/100	80/101
	40	Q [m ³ ·h ⁻¹]	4520	4788	5143	5497	5871	6316	6798	7263	7751
T ₃ [°C]		61	61	61	60	60	60	60	60	58	58
P _e [kW]		66,8	70,4	75,2	80,1	85,3	91,7	96,1	105,6	109,3	116,1
P _m [kW]		90	90	90	90	110	110	110	132	132	132
n [min ⁻¹]		1110	1166	1240	1314	1392	1485	1584	1683	1782	1882
n _m [min ⁻¹]		1480	1480	1480	1480	1485	1485	1485	1485	1485	1485
Elmotor		280-4	280-4	280-4	280-4	315-4	315-4	315-4	315-4	315-4	315-4
i		300/400	315/400	335/400	355/400	375/400	400/400	400/375	425/375	450/375	450/355
X		3/XPC	3/XPC	3/XPC	3/XPC	3/XPC	3/XPC	3/XPC	3/XPC	3/XPC	4/XPC
L _{mA} [dB]		75/96	75/97	76/98	77/98	77/98	78/99	79/100	79/100	80/101	81/102
50		Q [m ³ ·h ⁻¹]	4468	4732	5092	5447	5802	6247	6728	7200	7696
	T ₃ [°C]	72	71	71	71	70	70	70	70	68	68
	P _e [kW]	82,8	87,1	93	99	105	112,7	118,6	129,5	134,9	143,2
	P _m [kW]	110	110	110	110	132	132	132	160	160	160
	n [min ⁻¹]	1114	1169	1244	1318	1392	1485	1584	1684	1786	1886
	n _m [min ⁻¹]	1485	1485	1485	1485	1485	1485	1485	1485	1488	1488
	Elmotor	315-4	315-4	315-4	315-4	315-4	315-4	315-4	315-4	315-4	315-4
	i	300/400	315/400	335/400	355/400	375/400	400/400	400/375	425/375	450/375	450/355
	X	4/XPC	4/XPC	4/XPC	4/XPC	4/XPC	4/XPC	4/XPC	4/XPC	4/XPC	4/XPC
	L _{mA} [dB]	76/98	76/99	77/99	78/100	78/100	79/101	80/101	80/102	81/103	82/104
	60	Q [m ³ ·h ⁻¹]	4407	4671	5032	5387	5742	6188	6639	7100	7556
T ₃ [°C]		82	82	81	81	80	80	78	78	77	77
P _e [kW]		98,5	103,6	110,6	117,6	124,7	133,7	140,6	149,7	158,8	169,1
P _m [kW]		110	132	132	132	160	160	160	200	200	200
n [min ⁻¹]		1114	1169	1244	1318	1392	1485	1578	1674	1769	1875
n _m [min ⁻¹]		1485	1485	1485	1485	1485	1485	1485	1488	1488	1488
Elmotor		315-4	315-4	315-4	315-4	315-4	315-4	315-4	315-4	315-4	315-4
i		300/400	315/400	335/400	355/400	375/400	400/400	425/400	450/400	630/530	630/500
X		4/XPC	4/XPC	4/XPC	4/XPC	4/XPC	4/XPC	4/XPC	4/XPC	4/XPC	4/XPC
L _{mA} [dB]		77/100	77/100	78/101	79/101	79/102	80/103	81/103	81/104	82/105	83/106
70		Q [m ³ ·h ⁻¹]	4345	4711	5066	5429	5797	6152	6583	6948	7505
	T ₃ [°C]	93	93	92	90	89	89	88	88	87	87
	P _e [kW]	114,1	122,2	130,2	137,1	146,9	155,1	163	171,3	184,1	196
	P _m [kW]	132	160	160	160	200	200	200	200	250	250
	n [min ⁻¹]	1112	1188	1262	1337	1414	1488	1577	1653	1769	1875
	n _m [min ⁻¹]	1485	1485	1485	1485	1488	1488	1488	1488	1488	1488
	Elmotor	315-4	315-4	315-4	315-4	315-4	315-4	315-4	315-4	315-4	315-4
	i	375/500	400/500	425/500	450/500	475/500	500/500	530/500	500/450	630/530	630/500
	X	4/XPC	4/XPC	4/XPC	4/XPC	4/XPC	4/XPC	4/XPC	4/XPC	4/XPC	5/XPC
	L _{mA} [dB]	78/101	78/102	79/103	80/103	80/104	81/104	82/105	82/105	83/106	84/108
	80	Q [m ³ ·h ⁻¹]	4299	4665	5036	5393	5752	6108	6514	7004	7460
T ₃ [°C]		105	103	102	100	99	99	98	97	97	
P _e [kW]		129,8	139	148,5	156,2	167	176,2	187,6	197,6	209,5	
P _m [kW]		160	160	200	200	200	200	250	250	250	
n [min ⁻¹]		1112	1188	1265	1339	1414	1488	1572	1674	1769	
n _m [min ⁻¹]		1485	1485	1488	1488	1488	1488	1488	1488	1488	
Elmotor		315-4	315-4	315-4	315-4	315-4	315-4	315-4	315-4	315-4	
i		375/500	400/500	425/500	450/500	475/500	500/500	560/530	630/560	630/530	
X		4/XPC	4/XPC	4/XPC	4/XPC	4/XPC	4/XPC	4/XPC	4/XPC	5/XPC	
L _{mA} [dB]		78/102	78/102	79/103	80/103	81/104	81/104	82/105	82/106	83/107	
90		Q [m ³ ·h ⁻¹]									
	T ₃ [°C]										
	P _e [kW]										
	P _m [kW]										
	n [min ⁻¹]										
	n _m [min ⁻¹]										
	Elmotor										
	i										
	X										
	L _{mA} [dB]										
	100	Q [m ³ ·h ⁻¹]									
T ₃ [°C]											
P _e [kW]											
P _m [kW]											
n [min ⁻¹]											
n _m [min ⁻¹]											
Elmotor											
i											
X											
L _{mA} [dB]											

Δp [kPa]		DT120/1002 DN 300										
		6398	7343	7816	8090	8442	8977	9576	10284			
30	Q [m ³ ·h ⁻¹]	6398	7343	7816	8090	8442	8977	9576	10284			
	T ₃ [°C]	51	51	51	51	50	50	50	50			
	P _e [kW]	70,8	81,9	87,8	93,9	100,5	108	117	127,5			
	P _m [kW]	90	110	110	132	132	132	160	160			
	n [min ⁻¹]	1485	1683	1782	1884	1987	2104	2235	2384			
	n _m [min ⁻¹]	1485	1485	1485	1486	2980	2980	2980	2980			
	Elmotor	280-4	315-4	315-4	315-4	315-2	315-2	315-2	315-2			
	i	400/400	425/375	450/375	450/355	300/450	300/425	300/400	300/375			
	X	3/XPC	3/XPC	3/XPC	3/XPC	3/XPC	3/XPC	4/XPC	4/XPC			
	L _{mA} [dB]	77/98	79/99	79/100	80/101	82/103	82/103	82/103	82/103			
40	Q [m ³ ·h ⁻¹]	6316	7263	7741	8013	8367	8903	9600	10207			
	T ₃ [°C]	61	61	61	61	60	60	60	60			
	P _e [kW]	91,7	105,6	112,9	120,4	128,2	137,6	140,7	161,0			
	P _m [kW]	110	132	160	160	160	160	160	200			
	n [min ⁻¹]	1486	1684	1783	1884	1987	2104	2235	2384			
	n _m [min ⁻¹]	1486	1486	1486	1486	2980	2980	2980	2980			
	Elmotor	315-4	315-4	315-4	315-4	315-2	315-2	315-2	315-2			
	i	400/400	425/375	450/375	450/355	300/450	300/425	300/400	300/375			
	X	3/XPC	3/XPC	4/XPC	4/XPC	4/XPC	4/XPC	5/XPC	5/XPC			
	L _{mA} [dB]	78/99	79/100	80/101	81/102	84/106	84/106	84/106	84/106			
50	Q [m ³ ·h ⁻¹]	6252	7210	7688	7963	8304	8841	9442	10146			
	T ₃ [°C]	70	70	70	70	70	70	70	70			
	P _e [kW]	112,7	129,7	134,6	142,9	155,5	167,5	180,1	194,8			
	P _m [kW]	132	160	160	160	200	200	200	250			
	n [min ⁻¹]	1486	1684	1783	1884	1987	2104	2235	2384			
	n _m [min ⁻¹]	1486	1486	1486	1486	2980	2980	2980	2980			
	Elmotor	315-4	315-4	315-4	315-4	315-2	315-2	315-2	315-2			
	i	400/400	425/375	450/375	450/355	300/450	300/425	300/400	300/375			
	X	4/XPC	4/XPC	4/XPC	4/XPC	5/XPC	5/XPC	5/XPC	5/XPC			
	L _{mA} [dB]	79/101	80/102	81/103	82/104	84/106	84/106	84/106	84/106			
60	Q [m ³ ·h ⁻¹]	6203	7094	7636	7907	8251	8788	9390	9928			
	T ₃ [°C]	80	79	79	79	79	79	79	79			
	P _e [kW]	134	152,4	163,8	174,1	184,8	197,4	211,9	224,7			
	P _m [kW]	160	200	200	250	250	250	250	250			
	n [min ⁻¹]	1486	1674	1787	1885	1987	2104	2235	2347			
	n _m [min ⁻¹]	1486	1488	1488	1488	2980	2980	2980	2980			
	Elmotor	315-4	315-4	315-4	315-4	317-2	317-2	317-2	317-2			
	i	400/400	450/400	475/400	475/375	300/450	300/425	300/400	315/400			
	X	4/XPC	4/XPC	5/XPC	5/XPC	5/XPC	6/XPC	6/XPC	6/XPC			
	L _{mA} [dB]	80/103	81/104	82/105	83/106	85/107	85/107	85/107	85/107			
70	Q [m ³ ·h ⁻¹]	6152	7020	7591	7882	8332						
	T ₃ [°C]	90	89	89	89	89						
	P _e [kW]	155,1	175,6	189,5	200,6	213,2						
	P _m [kW]	200	200	250	250	250						
	n [min ⁻¹]	1488	1669	1788	1882	1987						
	n _m [min ⁻¹]	1488	2980	2980	2980	2980						
	Elmotor	315-4	315-2	317-2	317-2	317-2						
	i	500/500	280/500	300/500	300/475	300/450						
	X	4XPC	5/XPC	5/XPC	6/XPC	6/XPC						
	L _{mA} [dB]	81/105	82/106	83/106	84/108	85/110						
80	Q [m ³ ·h ⁻¹]	6108	6977	7548								
	T ₃ [°C]	100	99	99								
	P _e [kW]	176,2	199,4	215								
	P _m [kW]	200	250	250								
	n [min ⁻¹]	1488	1669	1788								
	n _m [min ⁻¹]	1488	2980	2980								
	Elmotor	315-4	317-2	317-2								
	i	500/500	280/500	300/500								
	X	5/XPC	5/XPC	5/XPC								
	L _{mA} [dB]	81/105	82/106	83/107								
90	Q [m ³ ·h ⁻¹]											
	T ₃ [°C]											
	P _e [kW]											
	P _m [kW]											
	n [min ⁻¹]											
	n _m [min ⁻¹]											
	Elmotor											
	i											
	X											
	L _{mA} [dB]											
100	Q [m ³ ·h ⁻¹]											
	T ₃ [°C]											
	P _e [kW]											
	P _m [kW]											
	n [min ⁻¹]											
	n _m [min ⁻¹]											
	Elmotor											
	i											
	X											
	L _{mA} [dB]											

CZ Agregáty

UK Blower packages

D Aggregate

RU Агрегаты

DT 4 (21 kg)

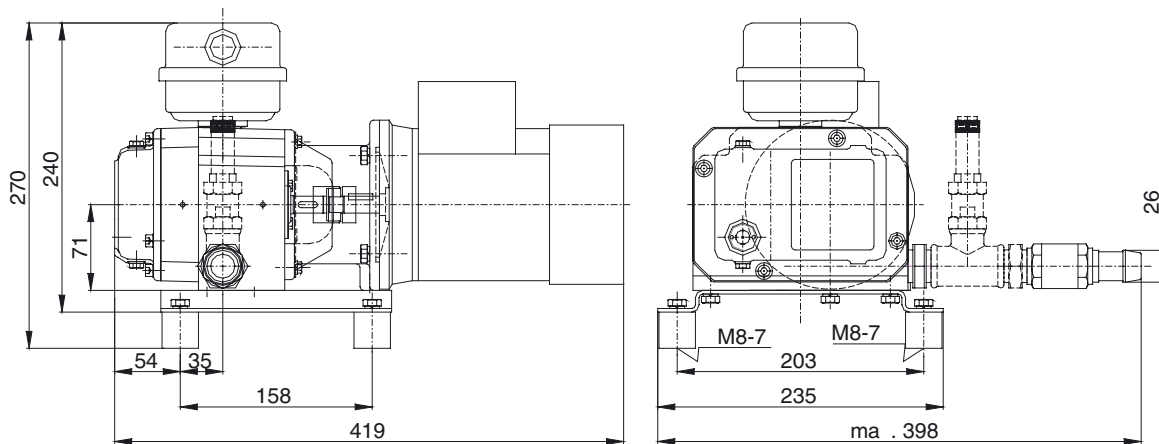

DT 4R (24 kg)

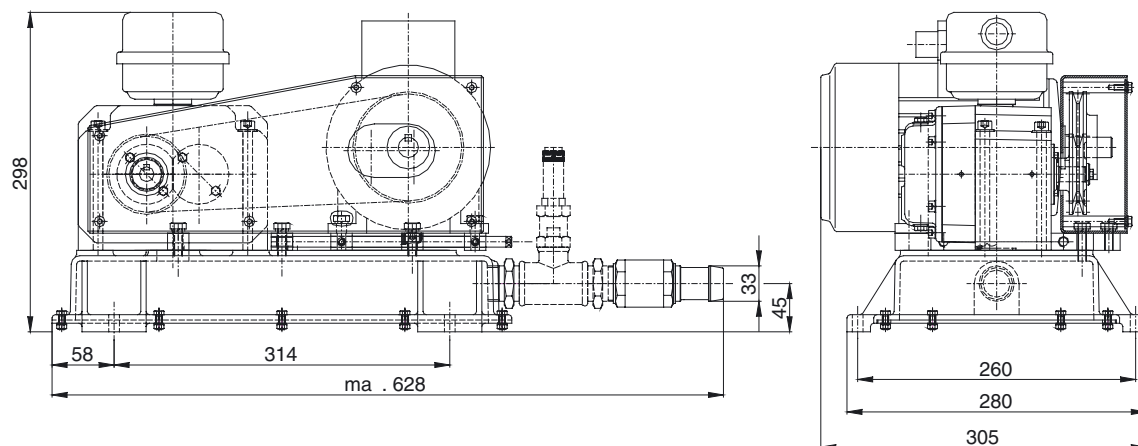

CZ Protihlukové kryty

UK Sound enclosures

D Schallhauben

RU Противозвучные кожухи

K 4 (20 kg)

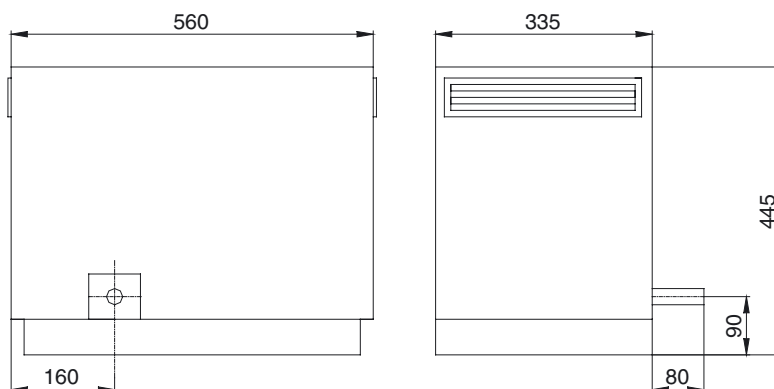

K 4R (22 kg)

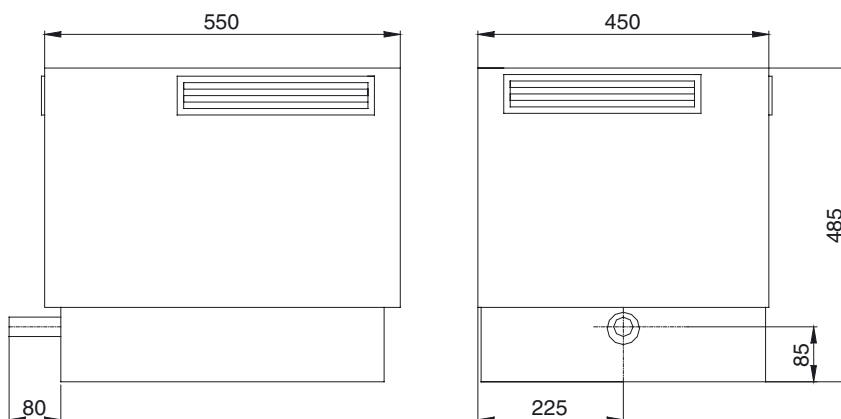

- CZ** Agregáty DT 6/42 až DT 120/1002
- UK** Blower packages DT 6/42 to DT 120/1002
- D** Aggregate DT 6/42 bis DT 120/1002
- RU** Агрегаты от DT 6/42 до DT 120/1002

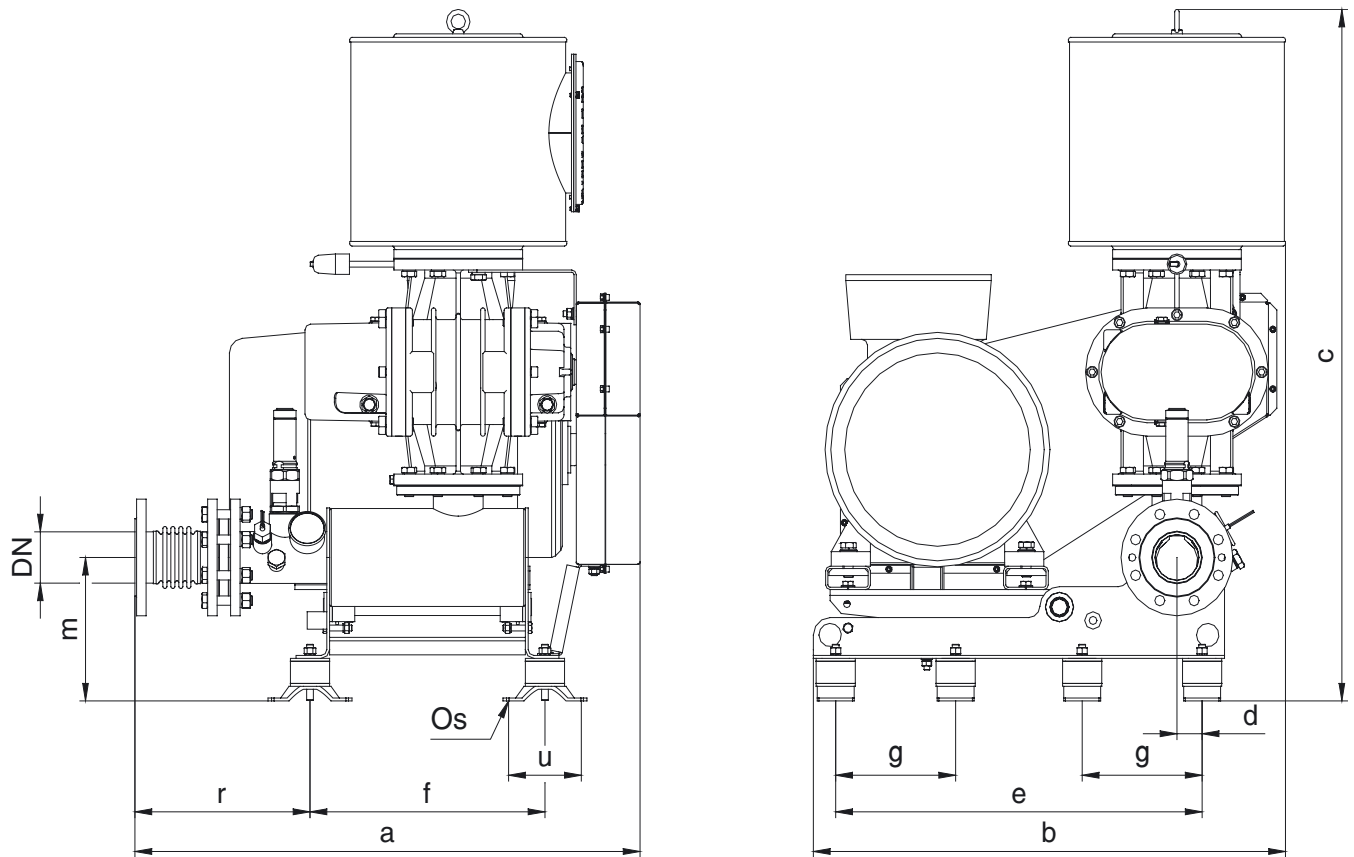

	a	b	c	d	e	f	g	k	m	u	r	s	DN	Kg **)	K ***)
DT 6/42	798	635	645	50	430	330	-	114	160	80	341	9	DN 65 / PN 10	77	K 42
DT 10/42	811	648	845	50	430	330	-	114	160	80	341	9	DN 65 / PN 10	91	K 42
DT 20/42	829	648	845	50	430	330	-	114	160	80	341	9	DN 65 / PN 10	95	K 42
DT 30/42	823	673	961	50	430	330	-	114	160	80	341	9	DN 65 / PN 10	120	K 42
DT 30/72	869	829	1065	45	655	420	-	40	246	130	313	13	DN 80 / PN 10	150	K 72
DT 40/72	895	829	1065	45	655	420	-	40	246	130	313	13	DN 80 / PN 10	160	K 72
DT 50/72	903	844	1186	45	655	420	-	40	246	130	313	13	DN 80 / PN 10	200	KN 72
DT 50/102	1025	869	1240	70	680	500	-	40	246	130	385	13	DN 100 / PN 10	230	K 102
DT 60/102	1049	869	1240	70	680	500	-	40	246	130	385	13	DN 100 / PN 10	245	K 102
DT 65/102	1085	883	1247	70	680	500	-	40	246	130	385	13	DN 100 / PN 10	325	K 102
DT 66/202	1227	1022	1336	188	940	600	-	40	250	130	444	13	DN 150 / PN 10	425	K 202
DT 66/202 *	1227	1056	1388	188	940	600	-	40	250	130	444	13	DN 150 / PN 10	450	K 202
DT 70/202	1324	1112	1518	188	940	600	-	40	250	130	444	13	DN 150 / PN 10	630	K 202
DT 70/302	1643	1320	1687	247	1200	700	-	60	413	144	727	13	DN 200 / PN 10	750	K 302
DT 90/302	1717	1369	1816	247	1200	700	-	60	413	144	727	13	DN 200 / PN 10	975	KN 302
DT 90/552	1829	1540	1932	300	1420	800	510	60	463	144	817	13	DN 250 / PN 10	1110	K 552
DT 100/552	1866	1597	2082	300	1420	800	510	60	463	144	817	13	DN 250 / PN 10	1375	K 552
DT 100/802	2063	1597	2082	300	1420	880	510	60	463	144	947	13	DN 300 / PN 10	1490	K 802
DT 110/802	2126	1597	2082	300	1420	880	510	60	463	144	947	13	DN 300 / PN 10	1710	K 802
DT 120/1002	2109	1600	2017	300	1420	880	510	60	463	144	947	13	DN 300 / PN 10	1810	K 1002

**))

- CZ** Hmotnost bez elektromotoru
- UK** Weight without el. Motor
- D** Gewicht ohne Elektromotor
- RU** Вес без электродвигателя

***))

- Protihlukový kryt
- Sound enclosure
- Schallschutzhaube
- Противошумный кожух

- CZ** Protihlukové kryty K 42 až K 202
- UK** Sound enclosures K 42 to K 202
- D** Schallhauben K 42 bis K 202
- RU** Противошумные кожухи от K 42 до K 202

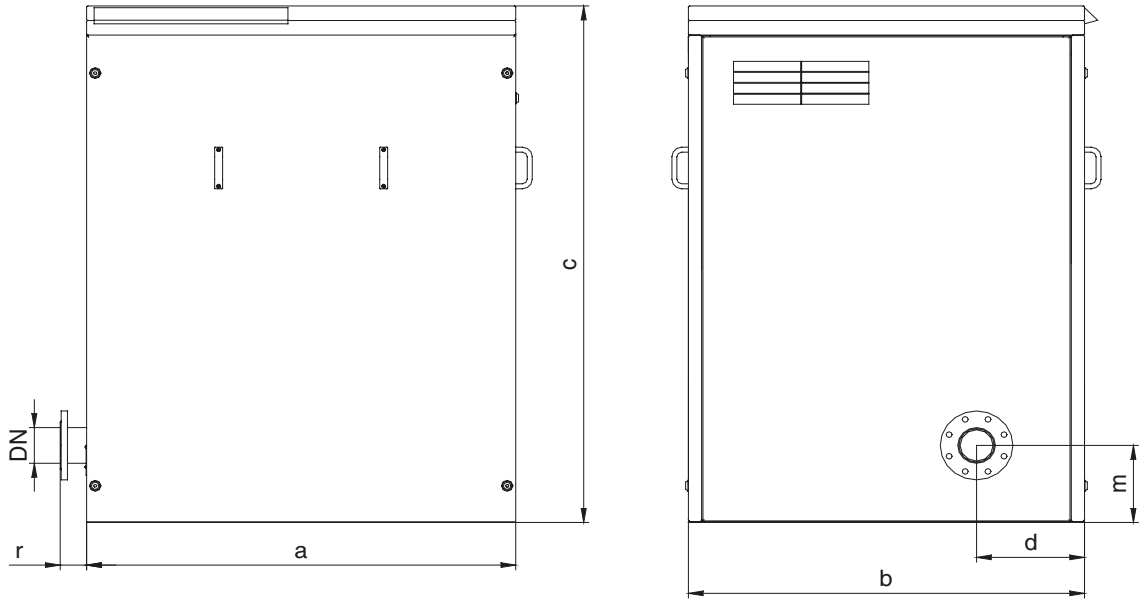

- CZ** Protihlukové kryty K 302 až K 1002
- UK** Sound enclosures K 302 to K 1002
- D** Schallhauben K 302 bis K 802
- RU** Противошумные кожухи от K 302 до K 1002

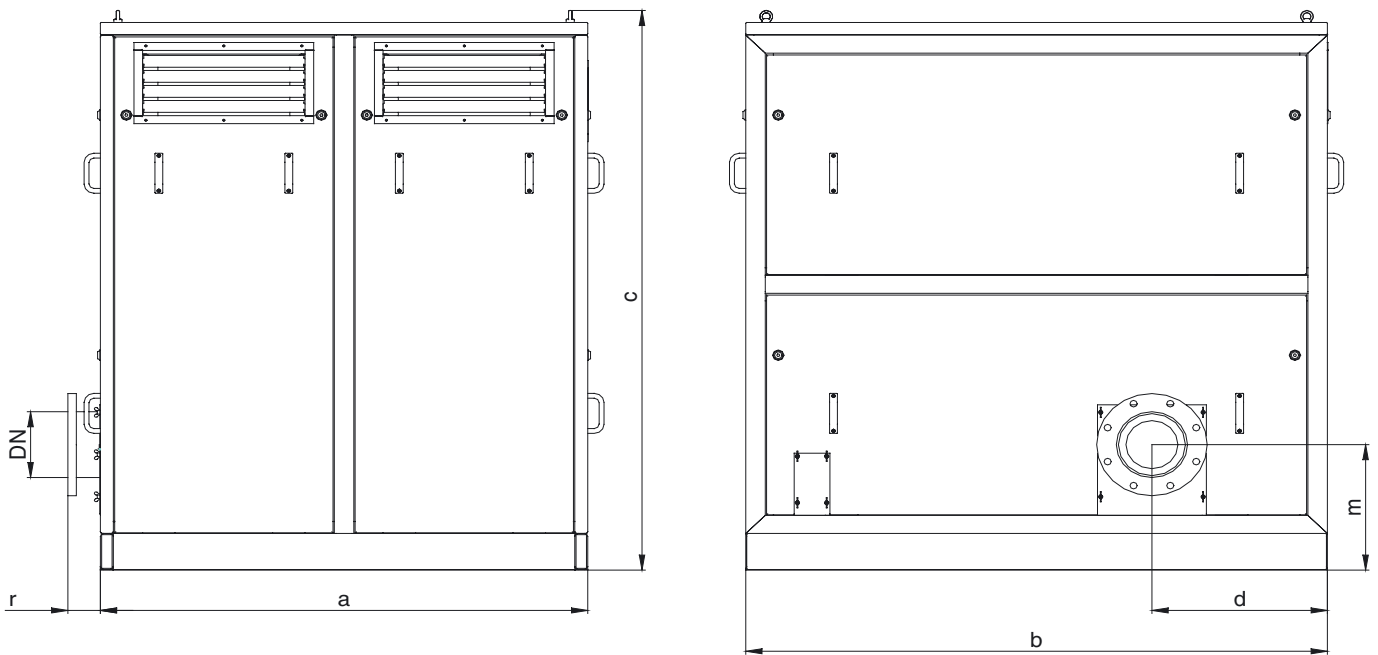

	a	b	c	d	m	r	DN	Ventilátor – Fan – Ventilator – Вентилятор	[kg]
K 42	780	882	1061	233	160	71	DN 65 / PN 10	HXTR/2-250 (0,11 kW; 400 V; 0,23 A)	120
K 72	1065	920	1261	221	248	74	DN 80 / PN 10	HCFT/4-315H (0,15 kW; 400 V; 0,34 A)	160
KN 72	1150	1000	1433	270	248	64	DN 80 / PN 10	HCFT/4-315H (0,15 kW; 400 V; 0,34 A)	186
K 102	1150	1000	1433	270	248	52	DN 100 / PN 10	HCFT/4-315H (0,15 kW; 400 V; 0,34 A)	186
K 202	1300	1200	1636	308	253	63	DN 150 / PN 10	HCFT/4-315H (0,15 kW; 400 V; 0,34 A)	220
K 302	1500	1790	1872	540	413	202	DN 200 / PN 10	HCFT/4-400H (0,32 kW; 400 V; 1,00 A)	490
KN 302	1650	1990	2192	649	413	200	DN 200 / PN 10	HCFT/4-450H (0,50 kW; 400 V; 1,00 A)	540
K 552	1650	1990	2192	674	463	255	DN 250 / PN 10	HCFT/4-450H (0,50 kW; 400 V; 1,00 A)	540
K 802	1990	1990	2192	674	463	255	DN 300 / PN 10	HCFT/4-500H (0,66 kW; 400 V; 1,55 A)	580
K 1002	1990	1990	2192	674	463	255	DN 300 / PN 10	HCFT/4-500H (0,66 kW; 400 V; 1,55 A)	580

🇨🇪 Ovládací rozvaděče s řídicí a kontrolní jednotkou pro dmychadla LUTOS

Dmychadlová soustrojí velikosti DT 6/42 až DT 120/1002 je možno kompletovat s ovládacími rozvaděči, které lze osadit řídicí a kontrolní jednotkou přímo od výrobce. Komplet se skládá z elektrického rozvaděče, osazeného elektrickými přístroji a jisticími prvky, které zajišťují spínání, chod a jističení motoru dmychadla

a ventilátoru. Druhou částí kompletu je logický automat firmy CMC. Jako základní provedení je použit typ AIRMASTER. Vlastní dmychadlové soustrojí má navíc snímač tlaku a teploty na výstupu. Dále je možnost vybavit rozvaděč frekvenčním měničem. Rozvaděče je možno připevnit na zeď nebo na konzole, které se upevní do země vedle dmychadla.

Základní funkce

Řízení motoru dmychadla

- zapnuto/vypnuto
- časování stykače pro přepnutí hvězda/trojúhelník

Funkce displeje

- tlak vzduchu na výstupu
- výstupní teplota (po stlačení tlačítka teploty)
- provozní hodiny (celkové, pro výměnu oleje atd. – voleno tlačítkem)

Funkce alarmu – signalizace, případně nouzové zastavení stroje

- překročení proudu motoru
- dosažení, případně překročení mezní teploty
- dosažení, případně překročení mezního tlaku na výstupu (zastavení stroje po časové prodlevě)
- zanesení filtru sání (při použití elektrického indikátoru zanesení filtru)

Při nouzovém zastavení stroje je třeba pro nové spuštění odstranit poruchu a stlačit tlačítko RESET. Řídicí systém je možno napojit na dálkové ovládání a monitorování chodu dmychadla.

Pro větší velikosti dmychadel, při požadavku dodávky proměnného množství vzduchu změnou otáček motoru dmychadla frekvenčním měničem, požadavku na řízení chodu dalšího dmychadla, případně požadavku většího počtu kontrolních funkcí je k dispozici logický automat Aircon L1 se dvěma tříčíslicovými displeji a jedním dvouřádkovým displejem alfanumerickým LCD.

Při zakoupení dmychadlového soustrojí včetně elektrického zařízení odpadá starost se zajišťováním elektrického ovládání. Po připojení potrubí k soustrojí a zapojení na elektrickou síť je dmychadlo připraveno ke spuštění. Použitím řídicího systému AIRMASTER M3AP případně Aircon L1 získá uživatel jednoduché, v oboru kompresorů ověřené řízení, které má všechny výhody řízení na bázi mikroprocesoru, ale je cenově srovnatelné s běžným elektromagnetickým ovládáním. Navíc má k dispozici časové údaje k provedení plánovaných údržbářských prací a hlídání mezních hodnot tlaku a teploty, které jsou důležité pro zabránění vzniku poruch dmychadla.

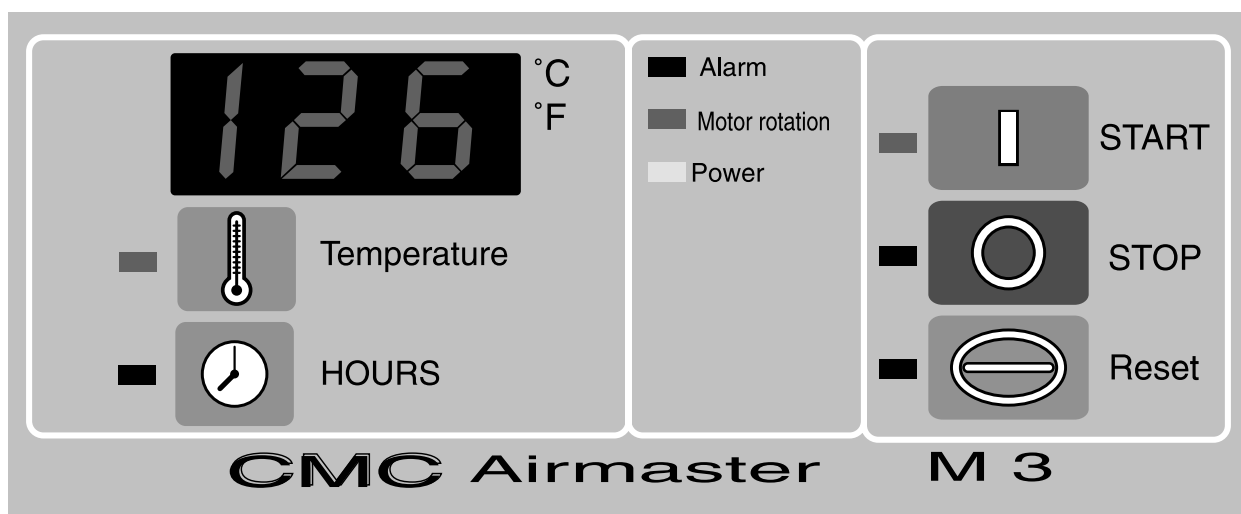

Ovládací panel obsahuje 5 tlačítek (spuštění a zastavení dmychadla, RESET, tlačítko pro zobrazení aktuální teploty resp. tlaku a tlačítko pro volbu počítání provozních hodin na displeji), 8 indikací LED (indikace funkce pěti tlačítek, alarm, chod motoru a připojení na el. síť) a tříčíslicový sedmisedimentový displej LED pro znázornění analogových hodnot tlaku a teploty, časových údajů a stavů pohonu.

Výkon motoru (kW)	Typ skříně	Váha (kg)	Rozměry š × v × h (mm)	Výkon motoru (kW)	Typ skříně	Váha (kg)	Rozměry š × v × h (mm)
1,1-2,2	plast	5	400×300×160	45	plast	16	700×500×270
3.4.2006	plast	5	400×300×160	55	plast	18	700×500×270
5,5	plast	5	400×300×160	75	plech	110	600×1600×400
7,5	plast	6	400×300×160	90	plech	120	600×1600×400
11	plast	6	400×300×160	110	plech	120	600×1600×400
15	plast	7	400×300×160	132	plech	130	600×1600×400
18,5	plast	7	400×300×160	160	plech	130	600×1600×400
22	plast	10	700×500×270	200	plech	150	800×1600×400
30	plast	12	700×500×270	250	plech	150	800×1600×400
37	plast	13	700×500×270				

UK Control unit for LUTOS air blower machine sets

The air blower machine sets of sizes DT 6/42 to DT 120/1002 supplied can be completed with switchboards, which can be equipped with control units directly from the manufacturer. The unit consists of an electric switchboard with electrical devices and safety circuits ensuring switching on/off, running and safety of the air blower and fan engine. The other part of the unit is a logic automat by CMC. The basic version is the AIRMASTER type. The air blower machine set has its own pressure and temperature sensors at output. Further, it is possible to equip the switchboard with a variable speed driver. The switch board can be mounted on the wall or on the bracket, which is fixed next to the blower.

Basic function

Air blower engine control

- on/off
- contactor timing to delta/star switching

Display function

- air pressure at output
- output temperature (after pushing temperature pushbutton)
- operation clock (total, for oil change etc. – selected by pushbutton)

Alarm functions – signaling or emergency stop

- exceeding engine current
- reaching or exceeding limit temperature
- reaching or exceeding limit pressure at output (machine stop at time delay)
- suction filter clogging (if electric filter clogging indicator is used)

During emergency stop, the error should be cleared and the RESET pushbutton must be pressed to start the device. The control unit can be connected to remote controlling and monitoring of the air blower operation.

For larger air blowers, Aircon L1 logic automat with two 3-digit displays and one two-line alpha-numeric LCD display is available if supplies of variable air quantity (using frequency converter to change engine revolutions) are required or if one more air blower or more controlling functions are required.

If the air blower machine set is purchased together with the electric devices, you have no problems associated with electric control. After connecting a pipeline to the machine set and upon connecting to the power system, the air blower is ready to run. Use of the AIRMASTER M3AP or Aircon L1 control system provides a user simple, field-tested device with all the benefits of a microprocessor-based device, but which is price-comparable to common solenoid controls. Moreover, the system has available time data to perform planned maintenance work and for monitoring of limit pressure and temperature values important for avoiding damage to the air blower.

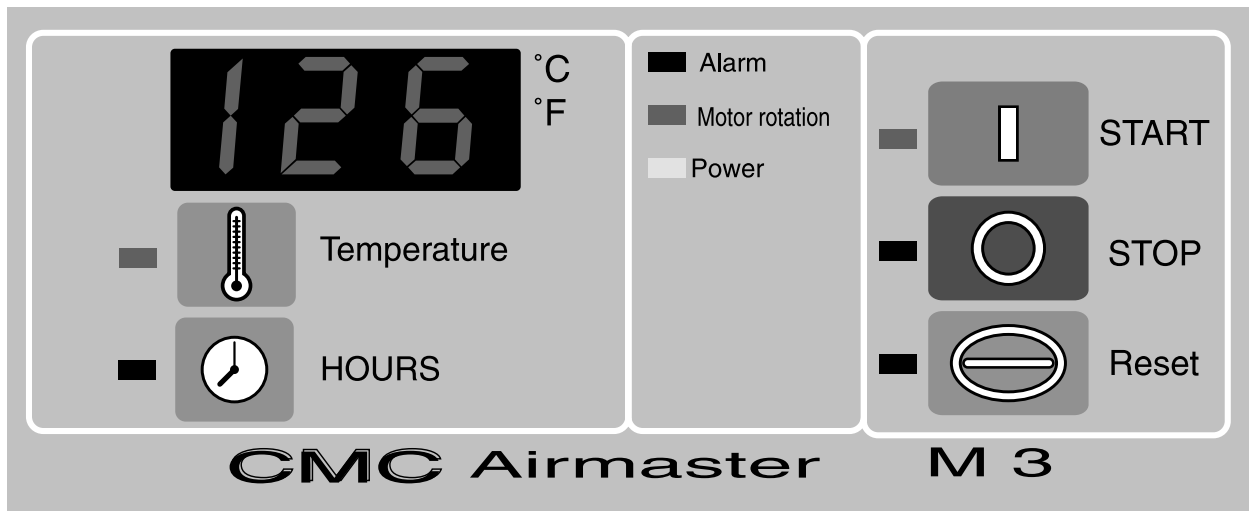

The control panel has five pushbuttons (air blower start/stop, reset, display current temperature/pressure, pushbutton for operating hours counting on display) 8 LED indicators (five pushbuttons indication, alarm, motor rotation and connection to power) and a three-digit 7-segment LED to display analogue values of pressure and temperature, time values and power status.

Motor load (kW)	Design of panel	Weight (kg)	Dimensions (mm)	Motor load (kW)	Design of panel	Weight (kg)	Dimensions (mm)
1,1-2,2	Plastic switch-board	5	400×300×160	45	Plastic switch-board	16	700×500×270
3,4.2006	Plastic switch-board	5	400×300×160	55	Plastic switch-board	18	700×500×270
5,5	Plastic switch-board	5	400×300×160	75	Steel switch-board	110	600×1600×400
7,5	Plastic switch-board	6	400×300×160	90	Steel switch-board	120	600×1600×400
11	Plastic switch-board	6	400×300×160	110	Steel switch-board	120	600×1600×400
15	Plastic switch-board	7	400×300×160	132	Steel switch-board	130	600×1600×400
18,5	Plastic switch-board	7	400×300×160	160	Steel switch-board	130	600×1600×400
22	Plastic switch-board	10	700×500×270	200	Steel switch-board	150	800×1600×400
30	Plastic switch-board	12	700×500×270	250	Steel switch-board	150	800×1600×400
37	Plastic switch-board	13	700×500×270				

D Steuer- und Kontrolleinheit für LUTOS Gebläseaggregate

Gebläseaggregate der Größen DT 6/42 bis DT 120/1002 können mit einer Schaltanlage mit Steuer- und Kontrolleinheit direkt vom Hersteller komplettiert werden. Diese Einheit besteht aus einem elektrischen Verteiler mit elektrischen Geräten und Sicherheitselementen, die die Schaltung, den Lauf und die Sicherung des Antriebsmotors des Gebläses und des Ventilators sichern. Den zweiten Teil der Einheit bildet der logische CMC Automat. Als Grundausführung wird der Typ AIRMASTER M3AP verwendet. Das eigene Gebläseaggregat hat weiter einen Druck- und einen Temperatursensor am Austritt. Weiter besteht hier die Möglichkeit die Schaltanlage mit einem Frequenzumrichter auszustatten. Die Einheit wird dann auf der Wand oder auf einem Träger montiert.

Grundfunktionen

Steuerung des Antriebsmotors

- ein/aus
- Zeitschalter für den Stern-Dreieck-Anlauf

Funktion des Displays

- Luftdruck am Austritt
- Temperatur am Austritt (nach dem Betätigen der Temperaturettaste)
- Betriebszeitmesser (Gesamtzeitmesser, für Ölwechsel usw. - per Tastendruck gewählt)

Funktion des Alarmes – Signalisierung, gegebenenfalls Notaußerbetriebsetzung des Gerätes

- Überschreiten des Stromes im Elektromotor
- Erreichen, beziehungsweise Überschreiten der Grenztemperatur
- Erreichen, beziehungsweise Überschreiten des Grenzdruckes am Austritt (Außerbetriebsetzung des Gerätes nach einer Zeitverzögerung)
- Verschmutzung des Ansaugfilters (bei Verwendung des elektrischen Indikators der Filterverschmutzung)

Nach einer Notaußerbetriebsetzung des Gerätes ist es notwendig, für einen neuen Anlauf den Defekt zu beseitigen und die RESET Taste zu drücken. Das Steuersystem kann an eine Fernbedienung und Überwachung des Gebläselaufes angeschlossen werden.

Für größere Gebläse, wenn das Zuströmen einer wechselbaren Luftmenge durch Verstellung der Drehzahl des Antriebsmotors mit Hilfe eines Frequenzschalters, oder die Steuerung eines weiteren Gebläses, oder eventuell eine größere Anzahl von Kontrollfunktionen angefordert werden, steht der logische Aircon L1 Automat mit zwei Dreiziffern-Displays und einem zweizeiligen alphanumerischen LCD Display, zur Verfügung.

Beim Kauf eines Gebläseaggregates inklusive elektrischer Einrichtung entfallen Sorgen mit der Anschaffung einer elektrischen Bedienung. Nach dem Anschluss der Rohrleitung ans Aggregat und Anschluss ans Stromnetz ist das Gebläseaggregat anlaufsbereit. Durch die Verwendung des AIRMASTER M3AP beziehungsweise Aircon L1 Steuersystems erhält der Nutzer eine einfache, im Bereich der Kompressoren bestätigte Steuerung, die alle Vorteile der Steuerung auf der Basis eines Mikroprozessors aufweist, im Preis jedoch mit üblicher elektromagnetischer Bedienung vergleichbar ist. Zusätzlich speichert es Zeitangaben über die Durchführung der geplanten Instandhaltungsarbeiten und überwacht die Druck- und Temperaturgrenzwerte, was zur Vorbeugung des Auftretens der Störfälle am Gebläseaggregat wichtig ist.

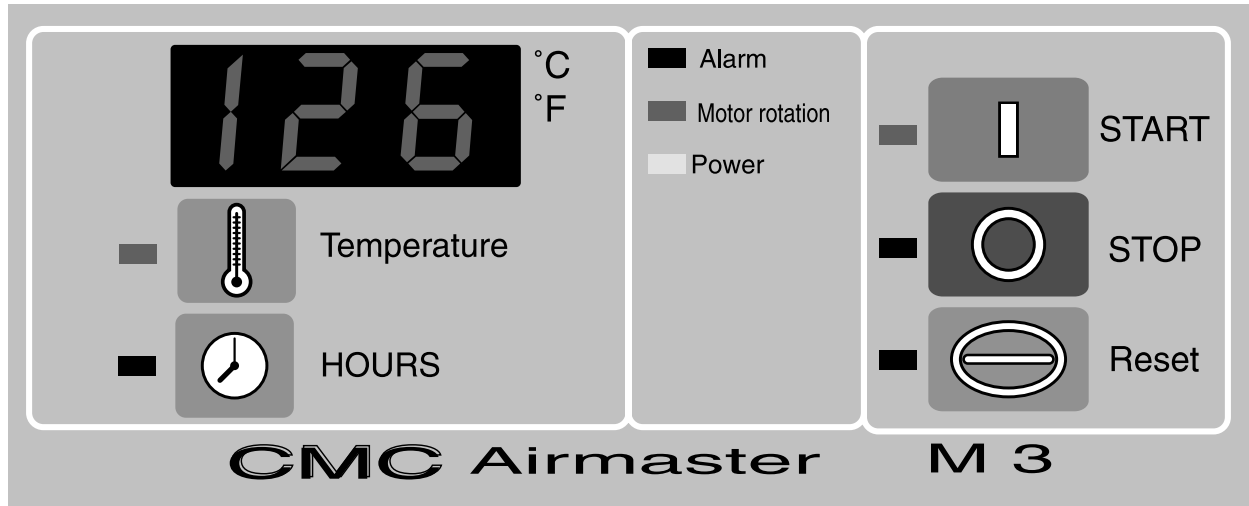

Das Betätigungspaneel hat 5 Tasten (Ein- und Ausschaltung des Gebläseaggregates, RESET, Taste für das Anzeigen der aktuellen Temperatur beziehungsweise des aktuellen Druckes und Taste für die Wahl der Betriebszeitählung auf dem Display), 8 LED-Anzeigen (Anzeige der Funktion der fünf Tasten, Alarm, Lauf des Antriebsmotors und Anschluss ans Stromnetz) und ein Dreiziffer-Siebensegment-LED Display für die Anzeige der Analogwerte des Druckes und der Temperatur, der Zeitangaben und des Antriebsstatus.

Motorleistung (kW)	Ausführung	Gewicht (kg)	Dimensionen (mm)	Motorleistung (kW)	Ausführung	Gewicht (kg)	Dimensionen (mm)
1,1-2,2	Kunststoff- Schaltanlage	5	400×300×160	45	Kunststoff- Schaltanlage	16	700×500×270
3.4.2006	Kunststoff- Schaltanlage	5	400×300×160	55	Kunststoff- Schaltanlage	18	700×500×270
5,5	Kunststoff- Schaltanlage	5	400×300×160	75	Pressblech- Schaltanlage	110	600×1600×400
7,5	Kunststoff- Schaltanlage	6	400×300×160	90	Pressblech- Schaltanlage	120	600×1600×400
11	Kunststoff- Schaltanlage	6	400×300×160	110	Pressblech- Schaltanlage	120	600×1600×400
15	Kunststoff- Schaltanlage	7	400×300×160	132	Pressblech- Schaltanlage	130	600×1600×400
18,5	Kunststoff- Schaltanlage	7	400×300×160	160	Pressblech- Schaltanlage	130	600×1600×400
22	Kunststoff- Schaltanlage	10	700×500×270	200	Pressblech- Schaltanlage	150	800×1600×400
30	Kunststoff- Schaltanlage	12	700×500×270	250	Pressblech- Schaltanlage	150	800×1600×400
37	Kunststoff- Schaltanlage	13	700×500×270				

RU Устройство управления и контроля для нагнетательных агрегатов «LUTOS»

Нагнетательные агрегаты размера «DT 6/42» - «DT 120/1002» можно комплектовать с устройством управления и контроля прямо от изготовителя. Устройство состоит из электрической разводной коробки, оборудованной электрическими приборами и защитными элементами, которые обеспечивают включение и выключение, ход и защиту двигателя нагнетателя, у агрегатов с противозумным кожухом – также вентилятора. Другой частью устройства является логический автомат фирмы «СМС». В качестве основного исполнения использован тип «AIRMASTER». Нагнетательные агрегаты имеют ещё и датчик давления и температуры на выходе. Электрическую разводную коробку можно комплектовать с преобразователем частоты.

Основные функции

Управление двигателем нагнетателя

- включен / выключен
- регулировка времени контактора для переключения звезда / треугольник

Функции дисплея

- давление воздуха на выходе
- температура на выходе (после нажатия кнопки температуры)
- рабочие часы (всего, для замены масла и т. д. – выбирается кнопкой)

Функция сигнализации неполадок – сигнализация или же аварийная остановка машины

- превышение тока двигателя
- достижение или же превышение предельной температуры
- достижение или же превышение предельного давления на выходе (остановка машины после временной задержки остановки)
- засорение фильтра всасывания (при использовании электрического индикатора засорения фильтра)

В случае аварийной остановки машины необходимо для нового запуска отстранить неисправность и нажать кнопку «RESET». Систему управления можно подсоединить к дистанционному управлению и слежению за работой нагнетателя.

Для больших размеров нагнетателей, при требовании подачи переменного количества воздуха путём изменения оборотов электродвигателя нагнетателя частотным преобразователем, при требовании управления ходом следующего нагнетателя или же при требовании большего количества контрольных функций имеется в распоряжении логический автомат «Aircon L1» с двумя трёхзначными дисплеями и одним двухрядным буквенно – цифровым дисплеем LCD.

При покупке нагнетательного агрегата вместе с электрическим оборудованием отпадают заботы по обеспечению электрического управления. После присоединения трубопровода к агрегату и подсоединения к электрической сети нагнетатель готов к пуску. Использование управляющей системы «AIRMASTER М3АР» или «Aircon L1» пользователь получит простое, проверенное на компрессорах управление, имеющее все выгоды микропроцессорной технологии, но и в ценовом отношении сравнимое с обычным электромагнитным управлением. К тому же пользователь имеет в своём распоряжении данные о времени пробега оборудования для проведения плановых работ по техническому обслуживанию нагнетателя и контролю предельных величин давления и температуры, которые являются важными для предотвращения поломок нагнетателя.

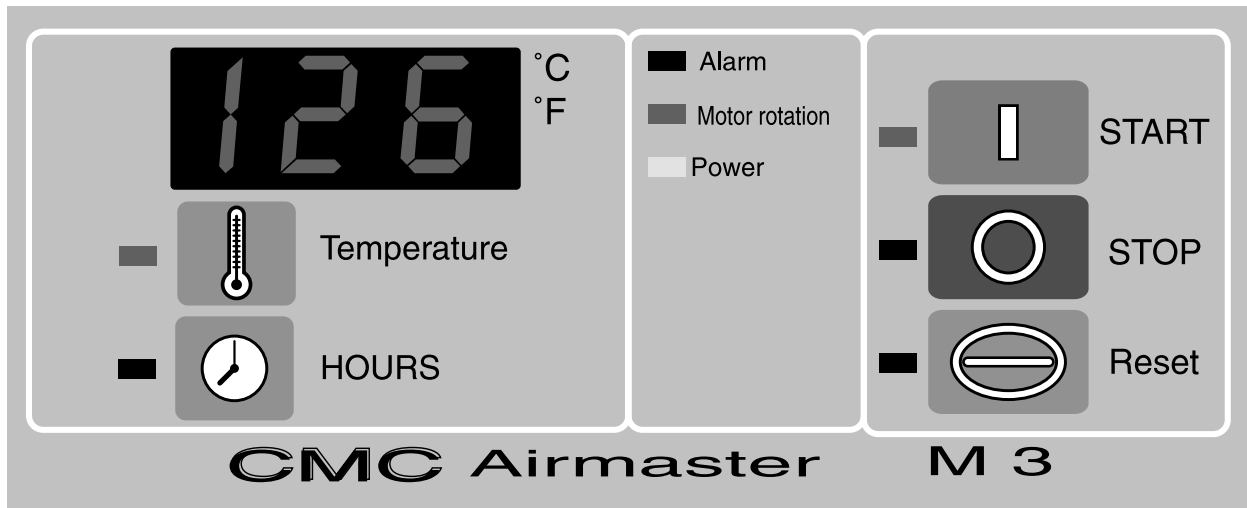

Панель управления имеет 5 кнопок (пуск и остановка нагнетателя, RESET (ПЕРЕЗАПУСК), кнопку для изображения актуальной температуры или давления и кнопку для выбора подсчёта рабочих часов на дисплее), 8 индикаторов «LED» (индикация функций пяти кнопок, сигнализация неполадок, ход двигателя и подключение к электрической сети) и трёхзначный семисегментный дисплей «LED» для визуального представления аналоговых величин давления и температуры, временных данных и состояний привода.

Мощность электродвигателя (кВ)	Проведение	Вес (кг)	Размеры (мм)	Мощность электродвигателя (кВ)	Проведение	Вес (кг)	Размеры (мм)
1,1-2,2	Пластовый шкаф	5	400×300×160	45	Пластовый шкаф	16	700×500×270
3,4.2006	Пластовый шкаф	5	400×300×160	55	Пластовый шкаф	18	700×500×270
5,5	Пластовый шкаф	5	400×300×160	75	Металлический шкаф	110	600×1600×400
7,5	Пластовый шкаф	6	400×300×160	90	Металлический шкаф	120	600×1600×400
11	Пластовый шкаф	6	400×300×160	110	Металлический шкаф	120	600×1600×400
15	Пластовый шкаф	7	400×300×160	132	Металлический шкаф	130	600×1600×400
18,5	Пластовый шкаф	7	400×300×160	160	Металлический шкаф	130	600×1600×400
22	Пластовый шкаф	10	700×500×270	200	Металлический шкаф	150	800×1600×400
30	Пластовый шкаф	12	700×500×270	250	Металлический шкаф	150	800×1600×400
37	Пластовый шкаф	13	700×500×270				

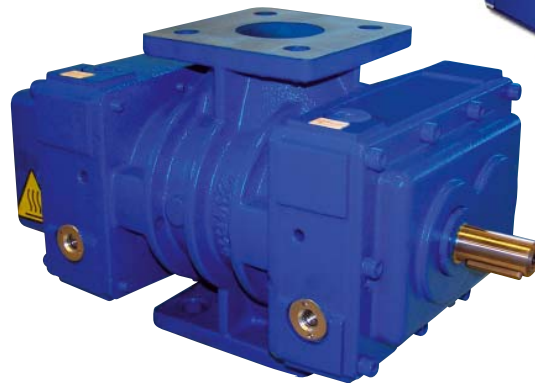

LUTOS a. s.
Pražská 183, 439 83 Lubenec
Tel.: +420 415 212 116, 415 212 117
Fax: +420 415 212 102
e-mail: lutos@lutos.cz
<http://www.lutos.cz>

LUTOS a. s.
Obchodní pobočka Brno
Hybešova 40, 602 00 Brno
Tel.: +420 543 211 100, 543 210 771
Fax: +420 543 211 100